

NORTH BEACH WATER DISTRICT

PACIFIC COUNTY

WASHINGTON



LIMITED PUBLIC WORKS CONTRACT

for

NORTH WELLFIELD SEPTIC SYSTEM INSTALLATION

BID REQUEST DATE: JUNE 10, 2015

BID DUE DATE: 11:00 PM JUNE 25, 2015

SMALL WORKS CONTRACT DOCUMENTS

TABLE OF CONTENTS

NORTH BEACH WATER DISTRICT

NORTH WELLFIELD SEPTIC SYSTEM INSTALLATION

TABLE OF CONTENTSTB-1

INVITATION TO BID.....IB-1

PART 1. LEGAL AND PROCEDURAL DOCUMENTS

BID PROPOSALBP-1 TO BP-4

CONTRACTC-1 TO C-8

PART 2. SPECIFICATIONS

TECHNICAL SPECIFICATIONS.....BP-1 TO BP-3

PART 3. PREVAILING WAGE RATES FOR PUBLIC WORKS CONTRACT

PREVAILING WAGE RATES.....PW-1 TO PW-17

PART 4. PLANS

VICINITY MAPS.....VM-1 TO VM-3

SEPTIC SYSTEM DESIGN.....D-1 to D-9

**NORTH BEACH WATER DISTRICT
LIMITED PUBLIC WORKS PROJECT
“PREVAILING WAGES SHALL BE PAID”**

INVITATION TO BID

The **NORTH BEACH WATER DISTRICT** is releasing a limited public works project to contracts on its small works roster listed for the scope of work category. As a Contractor, listed for the scope category, on the Small Works Roster, you are invited to submit a bid for this Project on the enclosed Bid Proposal Form.

Project Title: North Wellfield Septic System Installation.
Estimated project cost is \$5,500.00

Scope of Work: This project consists of installation of a gravity septic system consisting of a 1,250 gallon septic tank with 2 each 24” diameter PVC risers and 2 each 24 diameter fiberglass lids and 1 effluent filter; approximately 216’ of 4” sch. 40 PVC pipe and fittings; and a 420 square foot (10’ x 42’) drain field in compliance with all federal, state, and local regulations, and as show on the Plans and defined in the Specifications.

Bid Date: 11:00 am June 25, 2015

Questions about this project may be directed to William Neal, General Manager at (360) 244-0068 or by email at bneal@northbeachwater.com. Bidders shall submit all questions in writing. No oral responses to questions by District personnel about the project will be binding on the District.

The North Beach Water District expressly reserves the right to reject any of all bids and to waive minor irregularities or informalities, and to further make award of the project to the lowest responsive, responsible bidder as it best serves the interest of the District based on the sum of the Bid.

No Bid or Performance Bond will be required on this project. No retainage will be held from payment on this project.

The logo of the North Beach Water District is a circular emblem. It features a central illustration of a three-masted sailing ship on the water. The words "North Beach" are written in a cursive font along the top inner edge of the circle, and "Water District" is written along the bottom inner edge.

PART 1 – LEGAL AND PROCEDURAL DOCUMENTS

NORTH WELLFIELD SEPTIC SYSTEM INSTALLATION REQUEST FOR BIDS

JUNE, 2015

**NORTH WELLFIELD SEPTIC SYSTEM INSTALLATION
BID PROPOSAL**

TO: North Beach Water District
25902 Vernon Avenue
P.O. Box 618
Ocean Park, Washington 98640

1. The undersigned bidder proposed and agrees, if this Bid Proposal is accepted to enter into a Limited Public Works Contract (Contract) with the District. The Contract is included in the Contract Documents. The Bidder agrees to perform the work as stated in the Contract Documents. The Contract Documents include the Proposal, Contract, Specifications, and Plans.

2. Bidder accepts all of the terms and conditions of the Contract Documents, including without limitation those in the Invitation to Bid.

3. Bidder will enter into a Contract within the time and in the manner required in the Bid Proposal and Contract. Bidder will furnish the Insurance Certificates, Performance, Payment and Guaranty Bond required by the Contract Documents.

4. Bidder has examined copies of all the Contract Documents.

5. Bidder has familiarized itself with the nature and extent of the Contract Documents, work, site, locality where the work is to be performed, the legal requirements (federal, state, and local laws, ordinances, rules and regulations), and the conditions affecting cost, progress or performance of the work and has made such independent investigations as Bidder deems necessary.

6. This Bid is genuine and not made in the interest of or on behalf of any undisclosed person, firm or corporation and is not submitted in conformity with any agreement or rules of any group, association, organization or corporation; Bidder has not directly or indirectly induced or solicited any other Bidder to submit a false or sham Bid; Bidder has not solicited or induced any person, firm, or corporation to refrain from bidding; and Bidder has not sought by collusion to obtain for itself any advantage over any other Bidder or over District.

7. Bidder agrees not to withdraw the bid for a period of thirty (30) calendar days after the bid opening date unless otherwise required by law.

8. Bidder further agrees to complete the work required under the Contract within the Contract Time stipulated and to accept in full payment therefore the Contract Price based on the Total Bid Price(s) submitted herewith.

9. The undersigned agrees that the District reserves the right to reject any and all Proposals and to waive any minor irregularities and informalities in the Proposal. The undersigned agrees that the District reserves the right to award the contract to the lowest responsible, responsive bidder whose Proposal is in the best interest of the District.

**NORTH BEACH WATER DISTRICT
NORTH WELLFIELD WELL #2 DECOMMISSIONING
BID FORM**

Note: Bid prices for all items, all extensions and total amount of Bid must be shown below.

NO.	ITEM	QTY	UNITS	UNIT PRICE	AMOUNT
1	North Wellfield Septic System Installation	1	LS	\$ _____	\$ _____

Subtotal: \$ _____

Washington State Sales Tax (7.9%): \$ _____

TOTAL CONSTRUCTION COST: \$ _____

Subject to any extensions of the Contract time granted under the Contract, the undersigned agrees to complete the Work required under this Contract within 15 working days.

The undersigned has reviewed and fully understands the provisions in the Contract regarding liquidated damages and agrees that liquidated damages shall be \$100.00 per day for each and every work day beyond the Contract time allowed to complete the work.

ADDENDA RECEIVED

Addendum No.	Date Received	Name of Recipient

NOTE: Bidder shall acknowledge receipt of all addenda. Bidder is responsible for verifying the actual number of addenda issued prior to submitting a Proposal.

STATEMENT OF BIDDER'S QUALIFICATION

Number of years engaged in the construction business as the Bidding firm: _____

Number of years engaged in the construction of septic systems: _____

Gross dollar amount of work currently under contract: _____

Gross dollar of Contracts currently not completed _____

List of "3" major projects of a similar nature which have been completed by the Contractor within the last five years and the gross dollar amount of each project, together with the Owner's name and telephone number, and the Engineer's name:

Project Name	Amount	Owner	Phone	Engineer's Name

List the major pieces of equipment which are anticipated to be used on this project by the Contractor and note which items are owned by the Contractor and which are to be leased or rented from others:

The undersigned is in, and will remain in, full compliance with all Washington State Department of Licensing requirements for contractors, including but not limited to requirements for bond, proof of insurance and annual registration fee. The undersigned's Washington State:

Dept. of L & I Workman's Compensation Acct No. is: _____;

Dept. of Licensing Contractor's Registration No. is: _____;

Unified Business Identifier Number is: _____;

Excise Tax Registration Number is: _____; and

Employment Security Account Number is: _____.

Dated: _____

Bidder: _____

Address: _____

By: _____

Sign Name

Print Name

Title: _____

BIDDERS SHALL DELIVER THE PROPOSAL TO THE NORTH BEACH WATER DISTRICT, 25902 VERNON AVENUE, SUITE C, OCEAN PARK, WASHINGTON 98640, OR IF USPS POST OFFICE BOX 618, OCEAN PARK, WASHINGTON 98640-0618, TO BE OPENED BY THE DATE AND TIME INDICATED ON THE INVITATION TO BID. THE PROPOSAL SHALL BE SUBMITTED IN A SEALED PACKAGE, ADDRESSED TO THE OWNER AND PLAINLY MARKED **“PROPOSAL FOR NORTH WELLFIELD SEPTIC SYSTEM INSTALLATION” AND “ATTENTION JACK MCCARTY, OFFICE MANAGER.”** EMAILED OR FAXED PROPOSALS WILL NOT BE ACCEPTED.

LIMITED PUBLIC WORKS CONTRACT

THIS CONTRACT ("Contract") is made this _____ day of _____, 20____, between North Beach Water District ("District") and _____ ("Contractor").

In consideration of the terms and conditions contained herein and attached and made a part of this Contract, the parties herein covenant and agree as follows:

1. Project. The Contractor shall do all work and furnish all tools, materials and equipment for the District's public works project known as the **North Wellfield Septic System Installation** ("Project") in accordance with and as described in the Contract Documents including addenda (if any) described in the Bid Documents which are by this reference incorporated herein and made a part thereof, and shall perform any alterations in or additions to the Project provided under this Contract and every part thereof.

2. Project Cost. The amount of the Contract is _____ (\$ _____) plus applicable Washington State Slakes Tax. The Total Project cost includes all cost associated with the Project work, including but not limited to, labor, materials, overhead, administrative, permits, subcontractors, and regulatory costs unless otherwise agreed in writing. The District will pay sales tax at the rate assessed for unincorporated Pacific County to the Contractor for those portions of the Project that are subject to sales tax. The Contractor shall make sales tax and other tax payments to the State of Washington as provided by Washington State Law.

3. District Contract. The District hereby promises and agrees with the Contractor to employ and does employ the Contractor to provide the materials and to do and cause to be done the Project work required by the Contract Documents and to complete and finish same according to the Contract Documents.

4. Contractor Contract. The Contractor hereby agrees to fully perform the Project work in accord with the Contract Documents.

5. Liability. It is further provided that no liability shall attach to the District by reason of entering into this Contract except as expressly provided herein.

6. Completion Deadline/Liquidated Damages. The Project must be commenced

no later than Ten (10) working days from the date of mailing of the Notice to Proceed to the Contractor and must be finished no later than Fifteen (15) working days from the date of such mailing; if the Project is not completed within such time period, then because of the difficulty of computing the actual damages to the District arising from any delay in completing the Contract, the parties determine in advance and agree that the Contractor shall pay the District the amount of One Hundred Dollars (\$100.00) per work day that the work remains incomplete after expiration of the specified time for completion as liquidated damages, which the District will suffer by failure of the Contractor to complete the work within the agreed time. The execution of this Contract constitutes acknowledgement by the Contractor that Contractor has ascertained and agrees that the District will actually suffer damages of at least the amount herein fixed.

7. Contractor Responsibilities. The Contractor represents that Contractor is fully experienced and possesses all of the necessary expertise for performance of all work specified herein. The Contractor warrants to the District that any materials and equipment furnished under this Contract will be new and of good quality unless otherwise required or permitted by the Contract Documents, that the work will be free from defects, and that the work will conform to the requirements of the Contract Documents. Contractor shall return to the project and repair or replace all defects in workmanship and material discovered within one year after Final Acceptance of the Work. Contractor shall start work to remedy any such defects within seven (7) calendar days of receiving the District's written notice of a defect and shall complete such work within reasonable and mutually agreed time frame. In case of an emergency, where damage may result from delay or where loss of services may result, such corrections may be made by Owner's own forces or another contractor, in which case the cost of corrections shall be paid by Contractor. In the event Contractor does not accomplish corrections within the time specified, the work will be otherwise accomplished and the cost of same shall be paid by Contractor. When corrections of defects are made, Contractor shall then be responsible for correcting all defects in workmanship and materials in the corrected work for one year after acceptance of the corrections by the District. This guarantee is supplemental to and does not limit or affect the requirements that Contractor's work comply with the requirements of the Contract Documents or any other legal rights or remedies of the District.

8. Equitable Adjustments. Should the Contractor desire an equitable adjustment to the Project Cost, on the basis of a written change order or an oral order from the District, Contractor shall file a written notice of that fact with the District within 48 hours of the written or oral order. No later than seven days thereafter, Contractor shall file a written claim with the District stating the amount claimed supported by appropriate documentation. By not protesting or following procedures as this section

provides, the Contractor waives any additional entitlement or claims for protested work, and accepts from the District any written or oral order (including directions, instructions, interpretations, and determinations). In spite of any protest, the Contractor shall proceed to promptly complete work that the District has ordered. THE CONTRACTOR'S ACCEPTANCE OF FINAL PAYMENT SHALL CONSTITUTE A WAIVER OF CLAIMS, EXCEPT THOSE PREVIOUSLY AND PROPERLY MADE AND IDENTIFIED BY THE CONTRACTOR IN WRITING AS UNSETTLED AT THE TIME REQUEST FOR FINAL PAYMENT IS MADE.

9. Payment Terms.

9.1. Payments. The District shall pay the Contractor on a monthly basis for all work and services satisfactorily completed during the preceding month. A detailed application for payment shall be submitted by the Contractor to the District on or before the 30 day of each month, showing the progress of the work and requesting payment in an amount proportionate to the work completed. In cases of single payment, the District shall make payment only after all appropriate releases are submitted. In cases of multiple payments, the District shall retain monies as required by RCW 60.28 and pay the retainage as provided therein. Payment to the Contractor shall be made within 30 days after approval of the application for payment.

9.2. Defective or Unauthorized Work. The District reserves the right to withhold payment from the Contractor for any defective or unauthorized work. Defective or unauthorized work includes, without limitation: work and materials that do not conform to the requirements of this Contract, and extra work and materials furnished without the District's written approval. If the Contractor is unable, for any reason, to satisfactorily complete any portion of the work, the District may complete the work by contract or otherwise, and the Contractor shall be liable to the District for any additional costs incurred by the District. "Additional costs" means all reasonable costs incurred by the District, including legal costs and attorneys' fees, beyond the maximum contract price under this Contract. The District further reserves the right to deduct the cost to complete the work, including any additional costs, from any amounts due or to become due to the Contractor. The provisions of this subsection 8.2 shall be in addition to any other remedies available under this Contract.

10. Prevailing Wages Requirement. The Contractor shall pay prevailing wages in accord with RCW 39.12 and RCW 49.28. A statement of prevailing wages applicable to the Project is included in the specifications. Notice of intent to pay prevailing wages and prevailing wage rates for the project must be posted for the benefit of workers. The Contractor shall provide an "Affidavit of Industrial Insurance Compliance" for himself and each subcontractor upon acceptance of the Project by the District. Final payment will be made in accordance with the requirements of RCW 39.12.

11. Indemnification. The Contractor shall defend, indemnify, and

save the District and its officers and employees harmless from any and all claim and risk and all losses, damages, demands, suits, judgments, and attorneys' fees or other costs, penalties, fees or expenses of any kind on account of injury to or death of any and all persons, on account of all property damage of any kind, or loss of use resulting therefrom, or on account of liability under any federal, state or local laws, ordinances or regulations (including, but not limited to, those laws set forth in Section 17 below) governing the disposal of waste or debris accumulated and/or generated during the course of performance of the work under this Contract, that is in any manner connected with, the work performed under this Contract, or caused in whole or in part by reason of the presence of the contractor, the subcontractors, or their property, employees, or agents, upon or in proximity to the property of the District during performance of the work or at any time before final acceptance, except only for those losses resulting from and to the extent of the negligence of the District with regard to activities within the Contractor's scope of work. The Contractor specifically waives any immunity granted under the State Industrial Insurance Law, RCW Title 51, which is specifically acknowledged by the Contractor. _____
 (Contractor's Initials)

12. **Authority to Execute.** The undersigned warrant and represent they have full authority to execute this Contract for their respective entities and are fully authorized to do so.

13. **Insurance.** The Contractor shall obtain and keep in force during the term of the Contract, insurance in the following amounts:

	General	Automobile	Property	Completed Operations
Occurrence	\$2,000,000	\$2,000,000	\$2,000,000	\$2,000,000
Aggregate	\$2,000,000	\$2,000,000	\$2,000,000	\$2,000,000

The Contractor shall obtain endorsement forms CG 2010 07 04, CG 2032 07 04 and CG 2037 07 04 or the equivalent of each, naming the District and Gray & Osborne, Inc. as Additional Insured(s) and showing the policy number. If the Contractor is unsuccessful in securing these endorsements after exerting commercially reasonable efforts, the Contractor shall obtain other endorsements providing equivalent protection to the Additional Insured. A statement of additional insured status on an ACORD Certificate of Insurance shall not satisfy this requirement. Commercially reasonable efforts shall be evidenced by a signed statement by the Contractor's insurance broker indicating that endorsement forms CG 2010 07 04, CG 2032 07 04 and CG 2037 07 04 are not available and the endorsements submitted provide equivalent protection to the Additional Insured. A Certificate of Insurance and endorsement shall be executed and delivered to the District at the time of

execution of this Contract.

The following listed entities shall be named Additional Insured on all insurance policies:

- The District and its officers, elected officials, employees, agents and volunteers.

- _____

Providing coverage in the stated amounts shall not be construed to relieve the Contractor from liability in excess of such limits. The Contractor's insurance policies shall not contain deductibles or any self-insured retention in excess of \$10,000 unless approved by the District.

14. Safety. The Contractor shall be solely and completely responsible for safety and safety conditions on the jobsite, including the safety of all persons and property during performance of the Work. Observation of the Work by the District's employees, agents and consultants is not intended to include review of the Contractor's work methods, equipment, bracing, scaffolding or trenching, or safety measures in, on or near the construction site. The Contractor shall provide a safe access for the District and its employees, agents, and consultants to adequately observe the quality of the Work and the Contractor's conformance with the project specifications. The Contractor shall be solely and completely responsible to perform all work and furnish all materials in strict compliance with all applicable state, city, county and federal laws, regulations, ordinances, orders and codes. The Contractor's attention is directed to the requirements of the Washington Industrial Safety and Health Act (WISHA), Chapter 49.17 RCW.

15. Hours of Work. Contractor shall conduct all Work between the hours of 7:00 a.m. and 6:00 p.m. Monday through Friday unless stated otherwise under the Project's permit conditions or this Contract. No Work on weekends shall be allowed unless District gives written approval prior to the weekend. Contractor shall give a minimum of 48 hours' notice if Work on the weekend is necessary. Approved Work on the weekends shall be conducted between the hours of 7:00 a.m. and 6:00 p.m. Work hours may be further restricted due to permit conditions.

16. Specifications. Contractor shall furnish and install the materials and equipment and perform the work as specified on the Plans and in the Specifications and permits obtained for this Project.

17. Miscellaneous.

17.1. Subletting or Assigning Contract. The Contractor shall not assign, transfer, or encumber any rights, duties or interest accruing from this Contract without the express prior written consent of the District.

17.2. Extent of Contract Modification. This Contract, together with

attachments or addenda, represents the entire and integrated Contract between the parties and supersedes all prior negotiations, representations, or Contracts, either written or oral. This Contract may be amended, modified or added to only by written instrument properly signed by both parties.

17.3. Work Performed at Contractor's Risk. The Contractor shall take all precautions necessary and shall be responsible for the safety of its employees, agents, and subcontractors in the performance of work under this Contract. All work shall be done at the Contractor's own risk, and the Contractor shall be responsible for any loss of or damage to materials, tools, or other articles used or held for use in connection with the work.

17.4. Non-waiver of Breach. The failure of the District to insist upon strict performance of any of the terms and rights contained in this Contract, or to exercise any option contained in this Contract in one or more instances, shall not be construed to be a waiver or relinquishment of those terms and rights and such terms and rights shall remain in full force and effect.

17.5. Written Notice. All communications regarding this Contract shall be sent to the parties at the addresses listed below, unless otherwise notified. Any written notice shall become effective on delivery, but in any event on 3 calendar days after the date of mailing by registered or certified mail, and shall be deemed sufficiently given if sent to the addressee at the address stated in this Contract.

District

PO Box 618

Ocean Park, WA 98640

Contractor

17.6. Discrimination. The Contractor agrees not to discriminate against any employee or applicant for employment or any other person in the performance of this Contract because of race, creed, color, national origin, marital status, sex, age, disability, or other circumstance prohibited by federal, state or local law or ordinance, except for a bona fide occupational qualification.

17.7. Compliance with Laws. The Contractor shall comply with all federal, state and local laws, ordinances, regulations, and rules applicable to the work to be done under this Contract.

17.8. Severability. If any provision of this Contract is held invalid, the remainder shall not be affected thereby if such remainder would then continue to conform to the terms and requirements of applicable law, and shall continue in force and effect.

17.9. Venue and Attorneys' Fees. This Contract shall be interpreted under and pursuant to the laws of the State of Washington. Venue for any action brought to enforce any of the provisions of this Contract shall be in Pacific County Superior Court, and the substantially prevailing party shall be entitled to recover its reasonable costs, expenses and attorneys' fees incurred in the action.

EXECUTED THIS _____ DAY OF _____, 20____ by our signatures below:

CONTRACTOR:

By: _____

Its _____

Address: _____

Telephone: _____

Legal Entity: _____

Cont. License No.: _____

DISTRICT:

By _____

Its _____

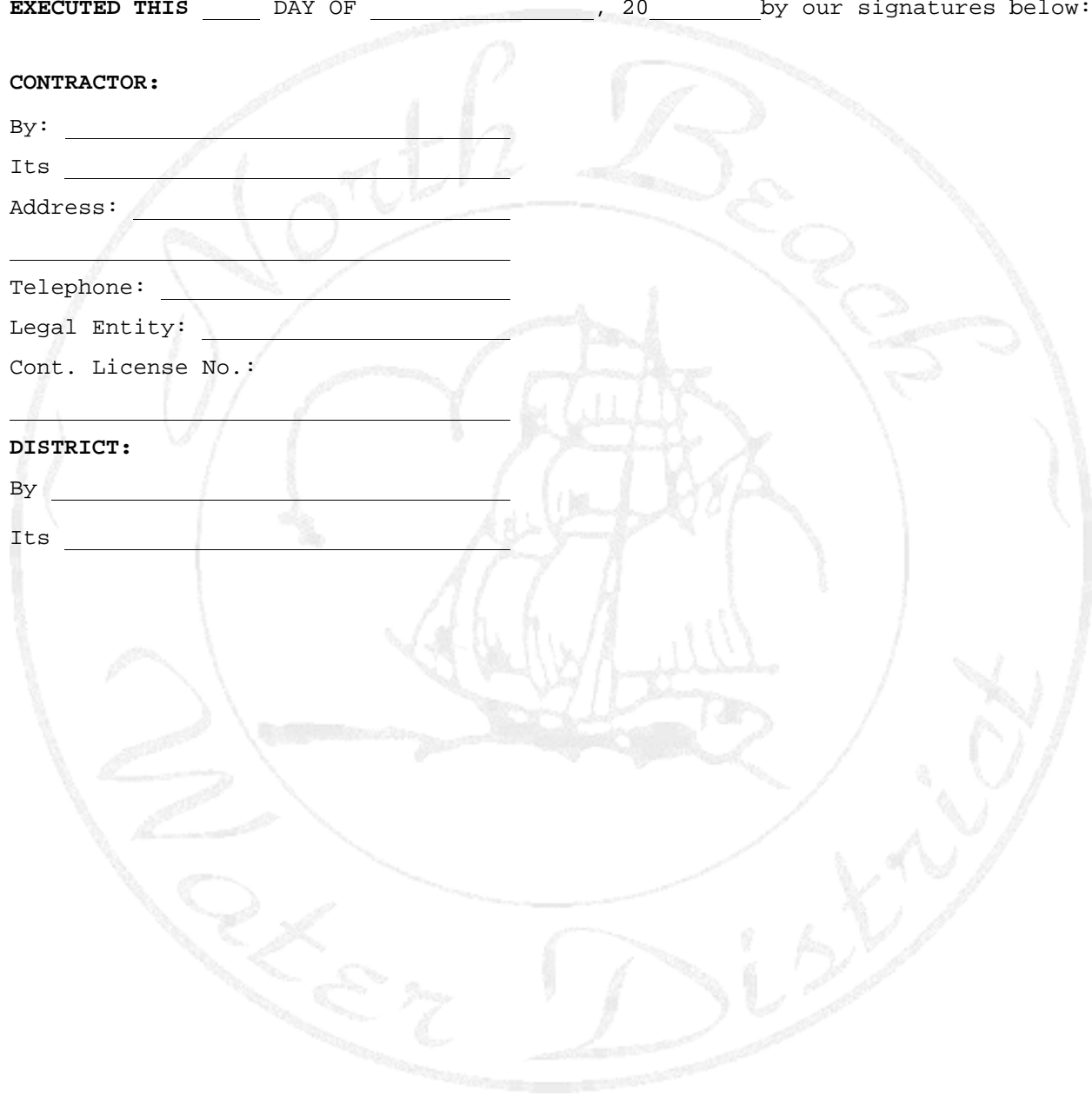



PART 2 – SPECIFICATIONS

NORTH WELLFIELD SEPTIC SYSTEM INSTALLATION REQUEST FOR BIDS

JUNE, 2015

TECHNICAL SPECIFICATIONS

Part 1 - Scope of Work

The scope of work includes the installation of a fully functional and compliant septic system in accordance with federal, state, and local regulations and the plans and specifications provided herein.

Part 2 - General

Access to site - The Contractor will have access to the Site by turning south off of 272nd Street onto the most easterly access driveway into the North Wellfield. The District will clearly identify with sign that has the Contractors Name on it as the authorized access point. The Contractor shall not deny the District access to the site at any time during decommissioning work.

Protection of Production Wells - The District maintains a series of production wells on the property. Their location in relationship to Well #2 are clearly identified in the Plans. The Contractor shall perform the work in a manner which protects the production wells and the immediately surrounding area from damage.

Notice to Proceed and Substantial Completion - Work shall be substantially completed within 15 working days of the Notice to Proceed. Work shall be completed between 7:00 a.m. and 6:00 p.m., Monday through Friday. Contractor shall coordinate schedule of work with the District.

Washington State Prevailing Wage - Contractor shall pay all laborers, workers and mechanics who work on this project Washington State Prevailing Wage Rates as required by Chapter 39.12 RCW. This requirement applies to all laborers, workers and mechanics employed by the Contractor, Subcontractor, or Subcontractors or any other person who performs a portion of the work defined as a part of this project. The prevailing wage rates as provide to the District by the Industrial Statistician of the Washington State Department of Labor and Industries are incorporated in the Contract Documents by reference as though fully set forth herein. In referring such rate the District does not imply or warrant that the Contractor will find labor available at those rates. It is the Contractor's sole responsibility to determine the most current wage rates it will actually have to pay. These rates shall remain in effect for the duration of the Contractor's performance of the Work.

Safety - Contractor shall be responsible for all safety requirements of employees, equipment, and the general public during construction. Contractor shall provide all necessary traffic control during the Project. The Contractor shall furnish, install and maintain all barricades, signs, lights, or other devices and provide flaggers as required.

Work Coordination - The septic system is related to a project being managed by a Project Manager under contract with the District to construct a facility to be served by the septic system. The Contractor will cooperate with and schedule all work with the District's Project Manager.

Tank Installation - Septic tank shall be installed and bedded in a manner that minimizes over excavation of the hole and assures it is:

- level;
- free from stones, rocks, or other objects that may cause damage; (especially to the bottom)
- free from organic material; (such as wood, roots, duff, etc.) that may decompose and result in settling)
- evenly supported throughout the entire area beneath the tank; and
- installed in accordance with the manufactures specifications.

Only use excavated material for back fill of the tank if it is free of rocks, boulders, or organic material.

Flow Line Installation - The flow line of the septic tank must be installed above the highest know seasonal water table.

Tight line Installation - When back filling connections between the building sewer and the septic tank, or where tight lines enter or exit the septic tank(s), compaction of the soil must be accomplished to a degree that will prevent sagging and broken joints over time.

Risers and Lids - Risers must be made from specified material and extend to a minimum of 2-inches above final grade. Risers will be fitted with fiberglass lids per the plans and specifications.

Installations under traffic Areas - When installing septic tanks, building sewers, and septic transport lines under concrete, asphalt, or gravel coverings where traffic is expected, provide the following:

- provide manufactures specifications confirming that all components used meet applicable load-bearing requirements.
- outfit all access risers and clean out with securable lids and bring to final grade over the manhole openings and baffle inspection ports.
- provide 1 cleanout every 50-feet on all septic transport lines.

Gravity Drain field - Perforated Pipe: Rigid, four-inch perforated (hole size 1/2" +/- 1/16") sewer pipe meeting the ASTM 3034 and ASTM F-679 standard and perforations meeting the ASTM D-2729 standard is required. Each lateral must be laid level with an end cap glued on the end.

Drain rock: A minimum of six inches of drain rock is required under the perforated pipe, and a minimum of two inches of drain rock is required over the perforated pipe. The drain rock shall be 1/2 to 2 1/2 inches in diameter, with no less than 100 percent passing a 2 1/2 inch sieve by weight and no more than five (5) percent passing a 1/2 inch sieve by weight, and shall be durable, clean, washed, non-deteriorating gravel free of organic materials. Other types of drain rock may be accepted on a case-by-case basis using the WSDOT standard as a guide. The drain rock must be covered with an approved geotextile (filter fabric) prior to backfilling the system.

Filter Fabric: Grab strength, 80 lbs. Puncture strength, 25 lbs. Trapezoid tear, 25 lbs. Apparent Opening, size AOS <0.297 MM or >#50 US Stand Sieve. Permeability, 0.4 cm/sec, fir soil types 1 & 2, 0.004 cm/sec for soil types >2.

Distribution Box: (if required) A minimum of 36 inches of ASTM 3034 tight line is required between the distribution box and the Drain field. The bottom of the inlet pipe will be a minimum of 1 inch above the bottom of the outlet pipes. The bottom of the outlet pipe will be a minimum of 2-inches above the floor of the distribution box. The distribution box will be installed so that it is stable, water tight, has a reliable removable cover, and will direct equal flow of effluent to all outlets.

Observation Ports: There will be a minimum of one observation port for each lateral. Observation ports will be made of 4" PVC (SDR 35). The 4" PVC pipe will be fitted to a 4" PVC tee on the branch end. The tee will be positioned to the bottom of the drain rock in the locations indicated in the septic design. Perforated end caps will be fitted on both ends of the 4" PVC tee so that water may freely enter the tee from both ends. The 4" PVC will extend to a minimum of 3-inches above final grade and be fitted with a removable cap.

Part 3 - Submittals

Preconstruction:

- Septic Tank
- effluent filter

Post Construction:

- As built drawings

Part 4 - Completion

Contractor shall leave site in a clean and tidy condition.

End of Section



PART 3 – PREVAILING WAGE RATES

NORTH WELLFIELD SEPTIC SYSTEM INSTALLATION REQUEST FOR BIDS

JUNE, 2015

State of Washington
 Department of Labor & Industries
 Prevailing Wage Section - Telephone 360-902-5335
 PO Box 44540, Olympia, WA 98504-4540

Washington State Prevailing Wage

The PREVAILING WAGES listed here include both the hourly wage rate and the hourly rate of fringe benefits. On public works projects, worker's wage and benefit rates must add to not less than this total. A brief description of overtime calculation requirements are provided on the Benefit Code Key.

Journey Level Prevailing Wage Rates for the Effective Date: 6/10/2015

<u>County</u>	<u>Trade</u>	<u>Job Classification</u>	<u>Wage</u>	<u>Holiday</u>	<u>Overtime</u>	<u>Note</u>
Pacific	Asbestos Abatement Workers	Journey Level	\$42.67	<u>5D</u>	<u>1H</u>	
Pacific	Boilermakers	Journey Level	\$64.29	<u>5N</u>	<u>1C</u>	
Pacific	Brick Mason	Brick And Block Finisher	\$44.46	<u>5A</u>	<u>1M</u>	
Pacific	Brick Mason	Journey Level	\$51.32	<u>5A</u>	<u>1M</u>	
Pacific	Brick Mason	Pointer-Caulker-Cleaner	\$51.32	<u>5A</u>	<u>1M</u>	
Pacific	Building Service Employees	Janitor	\$9.47		<u>1</u>	
Pacific	Building Service Employees	Shampooer	\$9.47		<u>1</u>	
Pacific	Building Service Employees	Waxer	\$9.47		<u>1</u>	
Pacific	Building Service Employees	Window Cleaner	\$13.22		<u>1</u>	
Pacific	Cabinet Makers (In Shop)	Journey Level	\$13.12		<u>1</u>	
Pacific	Carpenters	Acoustical Worker	\$52.32	<u>5D</u>	<u>4C</u>	
Pacific	Carpenters	Bridge, Dock And Wharf Carpenters	\$52.32	<u>5D</u>	<u>4C</u>	
Pacific	Carpenters	Carpenter	\$52.32	<u>5D</u>	<u>4C</u>	
Pacific	Carpenters	Carpenters on Stationary Tools	\$52.45	<u>5D</u>	<u>4C</u>	
Pacific	Carpenters	Creosoted Material	\$52.42	<u>5D</u>	<u>4C</u>	
Pacific	Carpenters	Floor Finisher	\$52.32	<u>5D</u>	<u>4C</u>	
Pacific	Carpenters	Floor Layer	\$52.32	<u>5D</u>	<u>4C</u>	
Pacific	Carpenters	Scaffold Erector	\$52.32	<u>5D</u>	<u>4C</u>	
Pacific	Cement Masons	Journey Level	\$35.33		<u>1</u>	
Pacific	Divers & Tenders	Diver	\$105.37	<u>5D</u>	<u>4C</u>	<u>8A</u>
Pacific	Divers & Tenders	Diver On Standby	\$59.50	<u>5D</u>	<u>4C</u>	
Pacific	Divers & Tenders	Diver Tender	\$54.82	<u>5D</u>	<u>4C</u>	
Pacific	Divers & Tenders	Surface Rcv & Rov Operator	\$54.82	<u>5D</u>	<u>4C</u>	
Pacific	Divers & Tenders	Surface Rcv & Rov Operator Tender	\$51.07	<u>5A</u>	<u>4C</u>	
Pacific	Dredge Workers	Assistant Engineer	\$54.75	<u>5D</u>	<u>3F</u>	
Pacific	Dredge Workers	Assistant Mate (Deckhand)	\$54.33	<u>5D</u>	<u>3F</u>	

Pacific	Dredge Workers	Boatmen	\$54.75	<u>5D</u>	<u>3F</u>	
Pacific	Dredge Workers	Engineer Welder	\$55.79	<u>5D</u>	<u>3F</u>	
Pacific	Dredge Workers	Leverman, Hydraulic	\$56.92	<u>5D</u>	<u>3F</u>	
Pacific	Dredge Workers	Mates	\$54.75	<u>5D</u>	<u>3F</u>	
Pacific	Dredge Workers	Oiler	\$54.33	<u>5D</u>	<u>3F</u>	
Pacific	Drywall Applicator	Journey Level	\$52.32	<u>5D</u>	<u>1H</u>	
Pacific	Drywall Tapers	Journey Level	\$15.00		<u>1</u>	
Pacific	Electrical Fixture Maintenance Workers	Journey Level	\$9.47		<u>1</u>	
Pacific	Electricians - Inside	Cable Splicer	\$61.96	<u>5C</u>	<u>1G</u>	
Pacific	Electricians - Inside	Journey Level	\$58.35	<u>5C</u>	<u>1G</u>	
Pacific	Electricians - Inside	Lead Covered Cable Splicer	\$65.55	<u>5C</u>	<u>1G</u>	
Pacific	Electricians - Inside	Welder	\$61.96	<u>5C</u>	<u>1G</u>	
Pacific	Electricians - Motor Shop	Craftsman	\$15.37		<u>1</u>	
Pacific	Electricians - Motor Shop	Journey Level	\$14.69		<u>1</u>	
Pacific	Electricians - Powerline Construction	Cable Splicer	\$69.95	<u>5A</u>	<u>4D</u>	
Pacific	Electricians - Powerline Construction	Certified Line Welder	\$63.97	<u>5A</u>	<u>4D</u>	
Pacific	Electricians - Powerline Construction	Groundperson	\$43.62	<u>5A</u>	<u>4D</u>	
Pacific	Electricians - Powerline Construction	Heavy Line Equipment Operator	\$63.97	<u>5A</u>	<u>4D</u>	
Pacific	Electricians - Powerline Construction	Journey Level Lineperson	\$63.97	<u>5A</u>	<u>4D</u>	
Pacific	Electricians - Powerline Construction	Line Equipment Operator	\$53.81	<u>5A</u>	<u>4D</u>	
Pacific	Electricians - Powerline Construction	Pole Sprayer	\$63.97	<u>5A</u>	<u>4D</u>	
Pacific	Electricians - Powerline Construction	Powderperson	\$47.55	<u>5A</u>	<u>4D</u>	
Pacific	Electronic Technicians	Journey Level	\$12.07		<u>1</u>	
Pacific	Elevator Constructors	Mechanic	\$83.01	<u>5N</u>	<u>4A</u>	
Pacific	Elevator Constructors	Mechanic In Charge	\$89.80	<u>5N</u>	<u>4A</u>	
Pacific	Fabricated Precast Concrete Products	Journey Level - In-Factory Work Only	\$13.50		<u>1</u>	
Pacific	Fence Erectors	Fence Erector	\$13.80		<u>1</u>	
Pacific	Fence Erectors	Fence Laborer	\$11.60		<u>1</u>	
Pacific	Flaggers	Journey Level	\$36.17	<u>7A</u>	<u>3I</u>	
Pacific	Glaziers	Journey Level	\$26.74	<u>5R</u>	<u>1Z</u>	
Pacific	Heat & Frost Insulators And Asbestos Workers	Journeyman	\$61.18	<u>5J</u>	<u>1S</u>	
Pacific	Heating Equipment Mechanics	Journey Level	\$70.37	<u>7F</u>	<u>1E</u>	
Pacific	Hod Carriers & Mason Tenders	Journey Level	\$44.00	<u>7A</u>	<u>3I</u>	
Pacific	Industrial Power Vacuum Cleaner	Journey Level	\$9.47		<u>1</u>	

Pacific	Inland Boatmen	Boat Operator	\$54.57	<u>5B</u>	<u>1K</u>	
Pacific	Inland Boatmen	Cook	\$50.95	<u>5B</u>	<u>1K</u>	
Pacific	Inland Boatmen	Deckhand	\$51.19	<u>5B</u>	<u>1K</u>	
Pacific	Inland Boatmen	Deckhand Engineer	\$52.18	<u>5B</u>	<u>1K</u>	
Pacific	Inland Boatmen	Launch Operator	\$53.40	<u>5B</u>	<u>1K</u>	
Pacific	Inland Boatmen	Mate	\$53.40	<u>5B</u>	<u>1K</u>	
Pacific	Inspection/Cleaning/Sealing Of Sewer & Water Systems By Remote Control	Cleaner Operator, Foamer Operator	\$9.73		<u>1</u>	
Pacific	Inspection/Cleaning/Sealing Of Sewer & Water Systems By Remote Control	Grout Truck Operator	\$11.48		<u>1</u>	
Pacific	Inspection/Cleaning/Sealing Of Sewer & Water Systems By Remote Control	Head Operator	\$12.78		<u>1</u>	
Pacific	Inspection/Cleaning/Sealing Of Sewer & Water Systems By Remote Control	Technician	\$9.47		<u>1</u>	
Pacific	Inspection/Cleaning/Sealing Of Sewer & Water Systems By Remote Control	Tv Truck Operator	\$10.53		<u>1</u>	
Pacific	Insulation Applicators	Journey Level	\$52.32	<u>5D</u>	<u>4C</u>	
Pacific	Ironworkers	Journey Level	\$48.33		<u>1</u>	
Pacific	Laborers	Air, Gas Or Electric Vibrating Screed	\$42.67	<u>7A</u>	<u>3I</u>	
Pacific	Laborers	Airtrac Drill Operator	\$44.00	<u>7A</u>	<u>3I</u>	
Pacific	Laborers	Ballast Regular Machine	\$42.67	<u>7A</u>	<u>3I</u>	
Pacific	Laborers	Batch Weighman	\$36.17	<u>7A</u>	<u>3I</u>	
Pacific	Laborers	Brick Pavers	\$42.67	<u>7A</u>	<u>3I</u>	
Pacific	Laborers	Brush Cutter	\$42.67	<u>7A</u>	<u>3I</u>	
Pacific	Laborers	Brush Hog Feeder	\$42.67	<u>7A</u>	<u>3I</u>	
Pacific	Laborers	Burner	\$42.67	<u>7A</u>	<u>3I</u>	
Pacific	Laborers	Caisson Worker	\$44.00	<u>7A</u>	<u>3I</u>	
Pacific	Laborers	Carpenter Tender	\$42.67	<u>7A</u>	<u>3I</u>	
Pacific	Laborers	Caulker	\$42.67	<u>7A</u>	<u>3I</u>	
Pacific	Laborers	Cement Dumper-paving	\$43.46	<u>7A</u>	<u>3I</u>	
Pacific	Laborers	Cement Finisher Tender	\$42.67	<u>7A</u>	<u>3I</u>	
Pacific	Laborers	Change House Or Dry Shack	\$42.67	<u>7A</u>	<u>3I</u>	
Pacific	Laborers	Chipping Gun (under 30 Lbs.)	\$42.67	<u>7A</u>	<u>3I</u>	
Pacific	Laborers	Chipping Gun(30 Lbs. And Over)	\$43.46	<u>7A</u>	<u>3I</u>	
Pacific	Laborers	Choker Setter	\$42.67	<u>7A</u>	<u>3I</u>	
Pacific	Laborers	Chuck Tender	\$42.67	<u>7A</u>	<u>3I</u>	
Pacific	Laborers	Clary Power Spreader	\$43.46	<u>7A</u>	<u>3I</u>	
Pacific	Laborers	Clean-up Laborer	\$42.67	<u>7A</u>	<u>3I</u>	
Pacific	Laborers	Concrete Dumper/chute Operator	\$43.46	<u>7A</u>	<u>3I</u>	

Pacific	Laborers	Concrete Form Stripper	\$42.67	<u>7A</u>	<u>3I</u>	
Pacific	Laborers	Concrete Placement Crew	\$43.46	<u>7A</u>	<u>3I</u>	
Pacific	Laborers	Concrete Saw Operator/core Driller	\$43.46	<u>7A</u>	<u>3I</u>	
Pacific	Laborers	Crusher Feeder	\$36.17	<u>7A</u>	<u>3I</u>	
Pacific	Laborers	Curing Laborer	\$42.67	<u>7A</u>	<u>3I</u>	
Pacific	Laborers	Demolition: Wrecking & Moving (incl. Charred Material)	\$42.67	<u>7A</u>	<u>3I</u>	
Pacific	Laborers	Ditch Digger	\$42.67	<u>7A</u>	<u>3I</u>	
Pacific	Laborers	Diver	\$44.00	<u>7A</u>	<u>3I</u>	
Pacific	Laborers	Drill Operator (hydraulic,diamond)	\$43.46	<u>7A</u>	<u>3I</u>	
Pacific	Laborers	Dry Stack Walls	\$42.67	<u>7A</u>	<u>3I</u>	
Pacific	Laborers	Dump Person	\$42.67	<u>7A</u>	<u>3I</u>	
Pacific	Laborers	Epoxy Technician	\$42.67	<u>7A</u>	<u>3I</u>	
Pacific	Laborers	Erosion Control Worker	\$42.67	<u>7A</u>	<u>3I</u>	
Pacific	Laborers	Faller & Bucker Chain Saw	\$43.46	<u>7A</u>	<u>3I</u>	
Pacific	Laborers	Fine Graders	\$42.67	<u>7A</u>	<u>3I</u>	
Pacific	Laborers	Firewatch	\$36.17	<u>7A</u>	<u>3I</u>	
Pacific	Laborers	Form Setter	\$42.67	<u>7A</u>	<u>3I</u>	
Pacific	Laborers	Gabian Basket Builders	\$42.67	<u>7A</u>	<u>3I</u>	
Pacific	Laborers	General Laborer	\$42.67	<u>7A</u>	<u>3I</u>	
Pacific	Laborers	Grade Checker & Transit Person	\$44.00	<u>7A</u>	<u>3I</u>	
Pacific	Laborers	Grinders	\$42.67	<u>7A</u>	<u>3I</u>	
Pacific	Laborers	Grout Machine Tender	\$42.67	<u>7A</u>	<u>3I</u>	
Pacific	Laborers	Groutmen (pressure)including Post Tension Beams	\$43.46	<u>7A</u>	<u>3I</u>	
Pacific	Laborers	Guardrail Erector	\$42.67	<u>7A</u>	<u>3I</u>	
Pacific	Laborers	Hazardous Waste Worker (level A)	\$44.00	<u>7A</u>	<u>3I</u>	
Pacific	Laborers	Hazardous Waste Worker (level B)	\$43.46	<u>7A</u>	<u>3I</u>	
Pacific	Laborers	Hazardous Waste Worker (level C)	\$42.67	<u>7A</u>	<u>3I</u>	
Pacific	Laborers	High Scaler	\$44.00	<u>7A</u>	<u>3I</u>	
Pacific	Laborers	Jackhammer	\$43.46	<u>7A</u>	<u>3I</u>	
Pacific	Laborers	Laserbeam Operator	\$43.46	<u>7A</u>	<u>3I</u>	
Pacific	Laborers	Maintenance Person	\$42.67	<u>7A</u>	<u>3I</u>	
Pacific	Laborers	Manhole Builder-mudman	\$43.46	<u>7A</u>	<u>3I</u>	
Pacific	Laborers	Material Yard Person	\$42.67	<u>7A</u>	<u>3I</u>	
Pacific	Laborers	Motorman-dinky Locomotive	\$43.46	<u>7A</u>	<u>3I</u>	
Pacific	Laborers	Nozzleman (concrete Pump, Green Cutter When Using Combination Of High Pressure	\$43.46	<u>7A</u>	<u>3I</u>	

		Air & Water On Concrete & Rock, Sandblast, Gunite, Shotcrete, Water Bla				
Pacific	Laborers	Pavement Breaker	\$43.46	<u>7A</u>	<u>3I</u>	
Pacific	Laborers	Pilot Car	\$36.17	<u>7A</u>	<u>3I</u>	
Pacific	Laborers	Pipe Layer Lead	\$44.00	<u>7A</u>	<u>3I</u>	
Pacific	Laborers	Pipe Layer/tailor	\$43.46	<u>7A</u>	<u>3I</u>	
Pacific	Laborers	Pipe Pot Tender	\$43.46	<u>7A</u>	<u>3I</u>	
Pacific	Laborers	Pipe Reliner	\$43.46	<u>7A</u>	<u>3I</u>	
Pacific	Laborers	Pipe Wrapper	\$43.46	<u>7A</u>	<u>3I</u>	
Pacific	Laborers	Pot Tender	\$42.67	<u>7A</u>	<u>3I</u>	
Pacific	Laborers	Powderman	\$44.00	<u>7A</u>	<u>3I</u>	
Pacific	Laborers	Powderman's Helper	\$42.67	<u>7A</u>	<u>3I</u>	
Pacific	Laborers	Power Jacks	\$43.46	<u>7A</u>	<u>3I</u>	
Pacific	Laborers	Railroad Spike Puller - Power	\$43.46	<u>7A</u>	<u>3I</u>	
Pacific	Laborers	Raker - Asphalt	\$44.00	<u>7A</u>	<u>3I</u>	
Pacific	Laborers	Re-timberman	\$44.00	<u>7A</u>	<u>3I</u>	
Pacific	Laborers	Remote Equipment Operator	\$43.46	<u>7A</u>	<u>3I</u>	
Pacific	Laborers	Rigger/signal Person	\$43.46	<u>7A</u>	<u>3I</u>	
Pacific	Laborers	Rip Rap Person	\$42.67	<u>7A</u>	<u>3I</u>	
Pacific	Laborers	Rivet Buster	\$43.46	<u>7A</u>	<u>3I</u>	
Pacific	Laborers	Rodder	\$43.46	<u>7A</u>	<u>3I</u>	
Pacific	Laborers	Scaffold Erector	\$42.67	<u>7A</u>	<u>3I</u>	
Pacific	Laborers	Scale Person	\$42.67	<u>7A</u>	<u>3I</u>	
Pacific	Laborers	Sloper (over 20")	\$43.46	<u>7A</u>	<u>3I</u>	
Pacific	Laborers	Sloper Sprayer	\$42.67	<u>7A</u>	<u>3I</u>	
Pacific	Laborers	Spreader (concrete)	\$43.46	<u>7A</u>	<u>3I</u>	
Pacific	Laborers	Stake Hopper	\$42.67	<u>7A</u>	<u>3I</u>	
Pacific	Laborers	Stock Piler	\$42.67	<u>7A</u>	<u>3I</u>	
Pacific	Laborers	Tamper & Similar Electric, Air & Gas Operated Tools	\$43.46	<u>7A</u>	<u>3I</u>	
Pacific	Laborers	Tamper (multiple & Self-propelled)	\$43.46	<u>7A</u>	<u>3I</u>	
Pacific	Laborers	Timber Person - Sewer (lagger, Shorer & Cribber)	\$43.46	<u>7A</u>	<u>3I</u>	
Pacific	Laborers	Toolroom Person (at Jobsite)	\$42.67	<u>7A</u>	<u>3I</u>	
Pacific	Laborers	Topper	\$42.67	<u>7A</u>	<u>3I</u>	
Pacific	Laborers	Track Laborer	\$42.67	<u>7A</u>	<u>3I</u>	
Pacific	Laborers	Track Liner (power)	\$43.46	<u>7A</u>	<u>3I</u>	
Pacific	Laborers	Traffic Control Laborer	\$38.68	<u>7A</u>	<u>3I</u>	<u>8R</u>
Pacific	Laborers	Traffic Control Supervisor	\$38.68	<u>7A</u>	<u>3I</u>	<u>8R</u>
Pacific	Laborers	Truck Spotter	\$42.67	<u>7A</u>	<u>3I</u>	
Pacific	Laborers	Tugger Operator	\$43.46	<u>7A</u>	<u>3I</u>	
Pacific	Laborers	Tunnel Work-Compressed Air Worker 0-30 psi	\$64.99	<u>7A</u>	<u>3I</u>	<u>8Q</u>

Pacific	Laborers	Tunnel Work-Compressed Air Worker 30.01-44.00 psi	\$70.02	<u>7A</u>	<u>3I</u>	<u>8Q</u>
Pacific	Laborers	Tunnel Work-Compressed Air Worker 44.01-54.00 psi	\$73.70	<u>7A</u>	<u>3I</u>	<u>8Q</u>
Pacific	Laborers	Tunnel Work-Compressed Air Worker 54.01-60.00 psi	\$79.40	<u>7A</u>	<u>3I</u>	<u>8Q</u>
Pacific	Laborers	Tunnel Work-Compressed Air Worker 60.01-64.00 psi	\$81.52	<u>7A</u>	<u>3I</u>	<u>8Q</u>
Pacific	Laborers	Tunnel Work-Compressed Air Worker 64.01-68.00 psi	\$86.62	<u>7A</u>	<u>3I</u>	<u>8Q</u>
Pacific	Laborers	Tunnel Work-Compressed Air Worker 68.01-70.00 psi	\$88.52	<u>7A</u>	<u>3I</u>	<u>8Q</u>
Pacific	Laborers	Tunnel Work-Compressed Air Worker 70.01-72.00 psi	\$90.52	<u>7A</u>	<u>3I</u>	<u>8Q</u>
Pacific	Laborers	Tunnel Work-Compressed Air Worker 72.01-74.00 psi	\$92.52	<u>7A</u>	<u>3I</u>	<u>8Q</u>
Pacific	Laborers	Tunnel Work-Guage and Lock Tender	\$44.10	<u>7A</u>	<u>3I</u>	<u>8Q</u>
Pacific	Laborers	Tunnel Work-Miner	\$44.10	<u>7A</u>	<u>3I</u>	<u>8Q</u>
Pacific	Laborers	Vibrator	\$43.46	<u>7A</u>	<u>3I</u>	
Pacific	Laborers	Vinyl Seamer	\$42.67	<u>7A</u>	<u>3I</u>	
Pacific	Laborers	Watchman	\$32.87	<u>7A</u>	<u>3I</u>	
Pacific	Laborers	Welder	\$43.46	<u>7A</u>	<u>3I</u>	
Pacific	Laborers	Well Point Laborer	\$43.46	<u>7A</u>	<u>3I</u>	
Pacific	Laborers	Window Washer/cleaner	\$32.87	<u>7A</u>	<u>3I</u>	
Pacific	Laborers - Underground Sewer & Water	General Laborer & Topman	\$42.67	<u>7A</u>	<u>3I</u>	
Pacific	Laborers - Underground Sewer & Water	Pipe Layer	\$43.46	<u>7A</u>	<u>3I</u>	
Pacific	Landscape Construction	Irrigation Or Lawn Sprinkler Installers	\$11.42		<u>1</u>	
Pacific	Landscape Construction	Landscape Equipment Operators Or Truck Drivers	\$9.47		<u>1</u>	
Pacific	Landscape Construction	Landscaping Or Planting Laborers	\$9.47		<u>1</u>	
Pacific	Lathers	Journey Level	\$52.32	<u>5D</u>	<u>1H</u>	
Pacific	Marble Setters	Journey Level	\$51.32	<u>5A</u>	<u>1M</u>	
Pacific	Metal Fabrication (In Shop)	Fitter	\$15.16		<u>1</u>	
Pacific	Metal Fabrication (In Shop)	Laborer	\$11.13		<u>1</u>	
Pacific	Metal Fabrication (In Shop)	Machine Operator	\$10.66		<u>1</u>	
Pacific	Metal Fabrication (In Shop)	Painter	\$11.41		<u>1</u>	
Pacific	Metal Fabrication (In Shop)	Welder	\$15.16		<u>1</u>	
Pacific	Millwright	Journey Level	\$53.42	<u>5D</u>	<u>4C</u>	
Pacific	Modular Buildings	Cabinet Assembly	\$9.98		<u>1</u>	
Pacific	Modular Buildings	Electrician	\$9.98		<u>1</u>	
Pacific	Modular Buildings	Equipment Maintenance	\$9.98		<u>1</u>	

Pacific	Modular Buildings	Plumber	\$9.98		<u>1</u>	
Pacific	Modular Buildings	Production Worker	\$9.75		<u>1</u>	
Pacific	Modular Buildings	Tool Maintenance	\$9.98		<u>1</u>	
Pacific	Modular Buildings	Utility Person	\$9.98		<u>1</u>	
Pacific	Modular Buildings	Welder	\$9.98		<u>1</u>	
Pacific	Painters	Journey Level	\$37.80	<u>6Z</u>	<u>2B</u>	
Pacific	Pile Driver	Journey Level	\$39.51		<u>1</u>	
Pacific	Plasterers	Journey Level	\$50.42	<u>7Q</u>	<u>1R</u>	
Pacific	Playground & Park Equipment Installers	Journey Level	\$9.47		<u>1</u>	
Pacific	Plumbers & Pipefitters	Journey Level	\$38.95		<u>1</u>	
Pacific	Power Equipment Operators	Asphalt Plant Operator	\$55.24	<u>7A</u>	<u>3C</u>	<u>8P</u>
Pacific	Power Equipment Operators	Assistant Engineers	\$51.97	<u>7A</u>	<u>3C</u>	<u>8P</u>
Pacific	Power Equipment Operators	Barrier Machine (zipper)	\$54.75	<u>7A</u>	<u>3C</u>	<u>8P</u>
Pacific	Power Equipment Operators	Batch Plant Operator: Concrete	\$54.75	<u>7A</u>	<u>3C</u>	<u>8P</u>
Pacific	Power Equipment Operators	Bobcat	\$51.97	<u>7A</u>	<u>3C</u>	<u>8P</u>
Pacific	Power Equipment Operators	Brokk - Remote Demolition Equipment	\$51.97	<u>7A</u>	<u>3C</u>	<u>8P</u>
Pacific	Power Equipment Operators	Brooms	\$51.97	<u>7A</u>	<u>3C</u>	<u>8P</u>
Pacific	Power Equipment Operators	Bump Cutter	\$54.75	<u>7A</u>	<u>3C</u>	<u>8P</u>
Pacific	Power Equipment Operators	Cableways	\$55.24	<u>7A</u>	<u>3C</u>	<u>8P</u>
Pacific	Power Equipment Operators	Chipper	\$54.75	<u>7A</u>	<u>3C</u>	<u>8P</u>
Pacific	Power Equipment Operators	Compressor	\$51.97	<u>7A</u>	<u>3C</u>	<u>8P</u>
Pacific	Power Equipment Operators	Concrete Pump: Truck Mount With Boom Attachment Over 42m	\$55.24	<u>7A</u>	<u>3C</u>	<u>8P</u>
Pacific	Power Equipment Operators	Concrete Finish Machine -laser Screed	\$51.97	<u>7A</u>	<u>3C</u>	<u>8P</u>
Pacific	Power Equipment Operators	Concrete Pump - Mounted Or Trailer High Pressure Line Pump, Pump High Pressure	\$54.33	<u>7A</u>	<u>3C</u>	<u>8P</u>
Pacific	Power Equipment Operators	Concrete Pump: Truck Mount With Boom Attachment Up To 42m	\$54.75	<u>7A</u>	<u>3C</u>	<u>8P</u>
Pacific	Power Equipment Operators	Conveyors	\$54.33	<u>7A</u>	<u>3C</u>	<u>8P</u>
Pacific	Power Equipment Operators	Cranes, 100 Tons - 199 Tons, Or 150 Ft Of Boom (including Jib With Attachments)	\$55.79	<u>7A</u>	<u>3C</u>	<u>8P</u>
Pacific	Power Equipment Operators	Cranes, 200 Tons To 300 Tons, Or 250 Ft Of Boom (including Jib With Attachments)	\$56.36	<u>7A</u>	<u>3C</u>	<u>8P</u>
Pacific	Power Equipment Operators	Cranes: 20 Tons Through 44 Tons With Attachments	\$54.75	<u>7A</u>	<u>3C</u>	<u>8P</u>
Pacific	Power Equipment Operators	Cranes: 45 Tons Through 99 Tons, Under 150' Of Boom (including Jib With	\$55.24	<u>7A</u>	<u>3C</u>	<u>8P</u>

		Attachments)				
Pacific	Power Equipment Operators	Cranes: A-frame - 10 Tons And Under	\$51.97	<u>7A</u>	<u>3C</u>	<u>8P</u>
Pacific	Power Equipment Operators	Cranes: Friction 100 Tons Through 199 Tons	\$56.36	<u>7A</u>	<u>3C</u>	<u>8P</u>
Pacific	Power Equipment Operators	Cranes: Friction Over 200 Tons	\$56.92	<u>7A</u>	<u>3C</u>	<u>8P</u>
Pacific	Power Equipment Operators	Cranes: Over 300 Tons, Or 300' Of Boom (Including Jib With Attachments)	\$56.92	<u>7A</u>	<u>3C</u>	<u>8P</u>
Pacific	Power Equipment Operators	Cranes: Through 19 Tons With Attachments A-frame Over 10 Tons	\$54.33	<u>7A</u>	<u>3C</u>	<u>8P</u>
Pacific	Power Equipment Operators	Crusher	\$54.75	<u>7A</u>	<u>3C</u>	<u>8P</u>
Pacific	Power Equipment Operators	Deck Engineer/deck Winches (power)	\$54.75	<u>7A</u>	<u>3C</u>	<u>8P</u>
Pacific	Power Equipment Operators	Derricks, On Building Work	\$55.24	<u>7A</u>	<u>3C</u>	<u>8P</u>
Pacific	Power Equipment Operators	Dozers D-9 & Under	\$54.33	<u>7A</u>	<u>3C</u>	<u>8P</u>
Pacific	Power Equipment Operators	Drill Oilers: Auger Type, Truck Or Crane Mount	\$54.33	<u>7A</u>	<u>3C</u>	<u>8P</u>
Pacific	Power Equipment Operators	Drilling Machine	\$54.75	<u>7A</u>	<u>3C</u>	<u>8P</u>
Pacific	Power Equipment Operators	Elevator And Man-lift: Permanent And Shaft Type	\$51.97	<u>7A</u>	<u>3C</u>	<u>8P</u>
Pacific	Power Equipment Operators	Finishing Machine, Bidwell And Gamaco & Similar Equipment	\$54.75	<u>7A</u>	<u>3C</u>	<u>8P</u>
Pacific	Power Equipment Operators	Forklift: 3000 Lbs And Over With Attachments	\$54.33	<u>7A</u>	<u>3C</u>	<u>8P</u>
Pacific	Power Equipment Operators	Forklifts: Under 3000 Lbs. With Attachments	\$51.97	<u>7A</u>	<u>3C</u>	<u>8P</u>
Pacific	Power Equipment Operators	Grade Engineer: Using Blueprints, Cut Sheets, etc.	\$54.75	<u>7A</u>	<u>3C</u>	<u>8P</u>
Pacific	Power Equipment Operators	Gradechecker/stakeman	\$51.97	<u>7A</u>	<u>3C</u>	<u>8P</u>
Pacific	Power Equipment Operators	Guardrail Punch	\$54.75	<u>7A</u>	<u>3C</u>	<u>8P</u>
Pacific	Power Equipment Operators	Hard Tail End Dump Articulating Off- Road Equipment 45 Yards. & Over	\$55.24	<u>7A</u>	<u>3C</u>	<u>8P</u>
Pacific	Power Equipment Operators	Hard Tail End Dump Articulating Off-road Equipment Under 45 Yards	\$54.75	<u>7A</u>	<u>3C</u>	<u>8P</u>
Pacific	Power Equipment Operators	Horizontal/directional Drill Locator	\$54.33	<u>7A</u>	<u>3C</u>	<u>8P</u>
Pacific	Power Equipment Operators	Horizontal/directional Drill Operator	\$54.75	<u>7A</u>	<u>3C</u>	<u>8P</u>
Pacific	Power Equipment Operators	Hydralifts/Boom Trucks Over 10 Tons	\$54.33	<u>7A</u>	<u>3C</u>	<u>8P</u>
Pacific	Power Equipment Operators	Hydralifts/boom Trucks, 10 Tons And Under	\$51.97	<u>7A</u>	<u>3C</u>	<u>8P</u>
Pacific	Power Equipment Operators	Loader, Overhead 8 Yards. & Over	\$55.79	<u>7A</u>	<u>3C</u>	<u>8P</u>

Pacific	Power Equipment Operators	Loader, Overhead, 6 Yards. But Not Including 8 Yards	\$55.24	<u>7A</u>	<u>3C</u>	<u>8P</u>
Pacific	Power Equipment Operators	Loaders, Overhead Under 6 Yards	\$54.75	<u>7A</u>	<u>3C</u>	<u>8P</u>
Pacific	Power Equipment Operators	Loaders, Plant Feed	\$54.75	<u>7A</u>	<u>3C</u>	<u>8P</u>
Pacific	Power Equipment Operators	Loaders: Elevating Type Belt	\$54.33	<u>7A</u>	<u>3C</u>	<u>8P</u>
Pacific	Power Equipment Operators	Locomotives, All	\$54.75	<u>7A</u>	<u>3C</u>	<u>8P</u>
Pacific	Power Equipment Operators	Material Transfer Device	\$54.75	<u>7A</u>	<u>3C</u>	<u>8P</u>
Pacific	Power Equipment Operators	Mechanics, All (Leadmen - \$0.50 Per Hour Over Mechanic)	\$55.79	<u>7A</u>	<u>3C</u>	<u>8P</u>
Pacific	Power Equipment Operators	Motor Patrol Grader - Non-finishing	\$54.33	<u>7A</u>	<u>3C</u>	<u>8P</u>
Pacific	Power Equipment Operators	Motor Patrol Graders, Finishing	\$55.24	<u>7A</u>	<u>3C</u>	<u>8P</u>
Pacific	Power Equipment Operators	Mucking Machine, Mole, Tunnel Drill, Boring, Road Header And/or Shield	\$55.24	<u>7A</u>	<u>3C</u>	<u>8P</u>
Pacific	Power Equipment Operators	Oil Distributors, Blower Distribution & Mulch Seeding Operator	\$51.97	<u>7A</u>	<u>3C</u>	<u>8P</u>
Pacific	Power Equipment Operators	Outside Hoists (elevators And Manlifts), Air Tuggers, strato	\$54.33	<u>7A</u>	<u>3C</u>	<u>8P</u>
Pacific	Power Equipment Operators	Overhead, Bridge Type Crane: 20 Tons Through 44 Tons	\$54.75	<u>7A</u>	<u>3C</u>	<u>8P</u>
Pacific	Power Equipment Operators	Overhead, Bridge Type: 100 Tons And Over	\$55.79	<u>7A</u>	<u>3C</u>	<u>8P</u>
Pacific	Power Equipment Operators	Overhead, Bridge Type: 45 Tons Through 99 Tons	\$55.24	<u>7A</u>	<u>3C</u>	<u>8P</u>
Pacific	Power Equipment Operators	Pavement Breaker	\$51.97	<u>7A</u>	<u>3C</u>	<u>8P</u>
Pacific	Power Equipment Operators	Pile Driver (other Than Crane Mount)	\$54.75	<u>7A</u>	<u>3C</u>	<u>8P</u>
Pacific	Power Equipment Operators	Plant Oiler - Asphalt, Crusher	\$54.33	<u>7A</u>	<u>3C</u>	<u>8P</u>
Pacific	Power Equipment Operators	Posthole Digger, Mechanical	\$51.97	<u>7A</u>	<u>3C</u>	<u>8P</u>
Pacific	Power Equipment Operators	Power Plant	\$51.97	<u>7A</u>	<u>3C</u>	<u>8P</u>
Pacific	Power Equipment Operators	Pumps - Water	\$51.97	<u>7A</u>	<u>3C</u>	<u>8P</u>
Pacific	Power Equipment Operators	Quad 9, HD 41, D10 And Over	\$55.24	<u>7A</u>	<u>3C</u>	<u>8P</u>
Pacific	Power Equipment Operators	Quick Tower - No Cab, Under 100 Feet In Height Based To Boom	\$51.97	<u>7A</u>	<u>3C</u>	<u>8P</u>
Pacific	Power Equipment Operators	Remote Control Operator On Rubber Tired Earth Moving Equipment	\$55.24	<u>7A</u>	<u>3C</u>	<u>8P</u>
Pacific	Power Equipment Operators	Rigger And Bellman	\$51.97	<u>7A</u>	<u>3C</u>	<u>8P</u>
Pacific	Power Equipment Operators	Rollagon	\$55.24	<u>7A</u>	<u>3C</u>	<u>8P</u>
Pacific	Power Equipment Operators	Roller, Other Than Plant Mix	\$51.97	<u>7A</u>	<u>3C</u>	<u>8P</u>
Pacific	Power Equipment Operators	Roller, Plant Mix Or Multi-lift Materials	\$54.33	<u>7A</u>	<u>3C</u>	<u>8P</u>
Pacific	Power Equipment Operators	Roto-mill, Roto-grinder	\$54.75	<u>7A</u>	<u>3C</u>	<u>8P</u>
Pacific	Power Equipment Operators	Saws - Concrete	\$54.33	<u>7A</u>	<u>3C</u>	<u>8P</u>

Pacific	Power Equipment Operators	Scraper, Self Propelled Under 45 Yards	\$54.75	<u>7A</u>	<u>3C</u>	<u>8P</u>
Pacific	Power Equipment Operators	Scrapers - Concrete & Carry All	\$54.33	<u>7A</u>	<u>3C</u>	<u>8P</u>
Pacific	Power Equipment Operators	Scrapers, Self-propelled: 45 Yards And Over	\$55.24	<u>7A</u>	<u>3C</u>	<u>8P</u>
Pacific	Power Equipment Operators	Service Engineers - Equipment	\$54.33	<u>7A</u>	<u>3C</u>	<u>8P</u>
Pacific	Power Equipment Operators	Shotcrete/gunite Equipment	\$51.97	<u>7A</u>	<u>3C</u>	<u>8P</u>
Pacific	Power Equipment Operators	Shovel , Excavator, Backhoe, Tractors Under 15 Metric Tons.	\$54.33	<u>7A</u>	<u>3C</u>	<u>8P</u>
Pacific	Power Equipment Operators	Shovel, Excavator, Backhoe: Over 30 Metric Tons To 50 Metric Tons	\$55.24	<u>7A</u>	<u>3C</u>	<u>8P</u>
Pacific	Power Equipment Operators	Shovel, Excavator, Backhoes, Tractors: 15 To 30 Metric Tons	\$54.75	<u>7A</u>	<u>3C</u>	<u>8P</u>
Pacific	Power Equipment Operators	Shovel, Excavator, Backhoes: Over 50 Metric Tons To 90 Metric Tons	\$55.79	<u>7A</u>	<u>3C</u>	<u>8P</u>
Pacific	Power Equipment Operators	Shovel, Excavator, Backhoes: Over 90 Metric Tons	\$56.36	<u>7A</u>	<u>3C</u>	<u>8P</u>
Pacific	Power Equipment Operators	Slipform Pavers	\$55.24	<u>7A</u>	<u>3C</u>	<u>8P</u>
Pacific	Power Equipment Operators	Spreader, Topsider & Screedman	\$55.24	<u>7A</u>	<u>3C</u>	<u>8P</u>
Pacific	Power Equipment Operators	Subgrader Trimmer	\$54.75	<u>7A</u>	<u>3C</u>	<u>8P</u>
Pacific	Power Equipment Operators	Tower Bucket Elevators	\$54.33	<u>7A</u>	<u>3C</u>	<u>8P</u>
Pacific	Power Equipment Operators	Tower Crane Over 175'in Height, Base To Boom	\$56.36	<u>7A</u>	<u>3C</u>	<u>8P</u>
Pacific	Power Equipment Operators	Tower Crane Up: To 175' In Height, Base To Boom	\$55.79	<u>7A</u>	<u>3C</u>	<u>8P</u>
Pacific	Power Equipment Operators	Transporters, All Track Or Truck Type	\$55.24	<u>7A</u>	<u>3C</u>	<u>8P</u>
Pacific	Power Equipment Operators	Trenching Machines	\$54.33	<u>7A</u>	<u>3C</u>	<u>8P</u>
Pacific	Power Equipment Operators	Truck Crane Oiler/driver - 100 Tons And Over	\$54.75	<u>7A</u>	<u>3C</u>	<u>8P</u>
Pacific	Power Equipment Operators	Truck Crane Oiler/driver Under 100 Tons	\$54.33	<u>7A</u>	<u>3C</u>	<u>8P</u>
Pacific	Power Equipment Operators	Truck Mount Portable Conveyor	\$54.75	<u>7A</u>	<u>3C</u>	<u>8P</u>
Pacific	Power Equipment Operators	Welder	\$55.24	<u>7A</u>	<u>3C</u>	<u>8P</u>
Pacific	Power Equipment Operators	Wheel Tractors, Farmall Type	\$51.97	<u>7A</u>	<u>3C</u>	<u>8P</u>
Pacific	Power Equipment Operators	Yo Yo Pay Dozer	\$54.75	<u>7A</u>	<u>3C</u>	<u>8P</u>
Pacific	Power Equipment Operators-Underground Sewer & Water	Asphalt Plant Operator	\$55.24	<u>7A</u>	<u>3C</u>	<u>8P</u>
Pacific	Power Equipment Operators-Underground Sewer & Water	Assistant Engineers	\$51.97	<u>7A</u>	<u>3C</u>	<u>8P</u>
Pacific	Power Equipment Operators-Underground Sewer & Water	Barrier Machine (zipper)	\$54.75	<u>7A</u>	<u>3C</u>	<u>8P</u>
Pacific	Power Equipment Operators-Underground Sewer & Water	Batch Plant Operator: Concrete	\$54.75	<u>7A</u>	<u>3C</u>	<u>8P</u>

Pacific	Power Equipment Operators-Underground Sewer & Water	Bobcat	\$51.97	<u>7A</u>	<u>3C</u>	<u>8P</u>
Pacific	Power Equipment Operators-Underground Sewer & Water	Brokk - Remote Demolition Equipment	\$51.97	<u>7A</u>	<u>3C</u>	<u>8P</u>
Pacific	Power Equipment Operators-Underground Sewer & Water	Brooms	\$51.97	<u>7A</u>	<u>3C</u>	<u>8P</u>
Pacific	Power Equipment Operators-Underground Sewer & Water	Bump Cutter	\$54.75	<u>7A</u>	<u>3C</u>	<u>8P</u>
Pacific	Power Equipment Operators-Underground Sewer & Water	Cableways	\$55.24	<u>7A</u>	<u>3C</u>	<u>8P</u>
Pacific	Power Equipment Operators-Underground Sewer & Water	Chipper	\$54.75	<u>7A</u>	<u>3C</u>	<u>8P</u>
Pacific	Power Equipment Operators-Underground Sewer & Water	Compressor	\$51.97	<u>7A</u>	<u>3C</u>	<u>8P</u>
Pacific	Power Equipment Operators-Underground Sewer & Water	Concrete Pump: Truck Mount With Boom Attachment Over 42m	\$55.24	<u>7A</u>	<u>3C</u>	<u>8P</u>
Pacific	Power Equipment Operators-Underground Sewer & Water	Concrete Finish Machine -laser Screed	\$51.97	<u>7A</u>	<u>3C</u>	<u>8P</u>
Pacific	Power Equipment Operators-Underground Sewer & Water	Concrete Pump - Mounted Or Trailer High Pressure Line Pump, Pump High Pressure	\$54.33	<u>7A</u>	<u>3C</u>	<u>8P</u>
Pacific	Power Equipment Operators-Underground Sewer & Water	Concrete Pump: Truck Mount With Boom Attachment Up To 42m	\$54.75	<u>7A</u>	<u>3C</u>	<u>8P</u>
Pacific	Power Equipment Operators-Underground Sewer & Water	Conveyors	\$54.33	<u>7A</u>	<u>3C</u>	<u>8P</u>
Pacific	Power Equipment Operators-Underground Sewer & Water	Cranes, 100 Tons - 199 Tons, Or 150 Ft Of Boom (including Jib With Attachments)	\$55.79	<u>7A</u>	<u>3C</u>	<u>8P</u>
Pacific	Power Equipment Operators-Underground Sewer & Water	Cranes, 200 Tons To 300 Tons, Or 250 Ft Of Boom (including Jib With Attachments)	\$56.36	<u>7A</u>	<u>3C</u>	<u>8P</u>
Pacific	Power Equipment Operators-Underground Sewer & Water	Cranes: 20 Tons Through 44 Tons With Attachments	\$54.75	<u>7A</u>	<u>3C</u>	<u>8P</u>
Pacific	Power Equipment Operators-Underground Sewer & Water	Cranes: 45 Tons Through 99 Tons, Under 150' Of Boom (including Jib With Attachments)	\$55.24	<u>7A</u>	<u>3C</u>	<u>8P</u>
Pacific	Power Equipment Operators-Underground Sewer & Water	Cranes: A-frame - 10 Tons And Under	\$51.97	<u>7A</u>	<u>3C</u>	<u>8P</u>
Pacific	Power Equipment Operators-Underground Sewer & Water	Cranes: Friction 100 Tons Through 199 Tons	\$56.36	<u>7A</u>	<u>3C</u>	<u>8P</u>
Pacific	Power Equipment Operators-Underground Sewer & Water	Cranes: Friction Over 200 Tons	\$56.92	<u>7A</u>	<u>3C</u>	<u>8P</u>
Pacific	Power Equipment Operators-Underground Sewer & Water	Cranes: Over 300 Tons, Or 300' Of Boom (Including Jib With Attachments)	\$56.92	<u>7A</u>	<u>3C</u>	<u>8P</u>
Pacific	Power Equipment Operators-Underground Sewer & Water	Cranes: Through 19 Tons With Attachments A-frame Over 10	\$54.33	<u>7A</u>	<u>3C</u>	<u>8P</u>

		Tons				
Pacific	Power Equipment Operators-Underground Sewer & Water	Crusher	\$54.75	<u>7A</u>	<u>3C</u>	<u>8P</u>
Pacific	Power Equipment Operators-Underground Sewer & Water	Deck Engineer/deck Winches (power)	\$54.75	<u>7A</u>	<u>3C</u>	<u>8P</u>
Pacific	Power Equipment Operators-Underground Sewer & Water	Derricks, On Building Work	\$55.24	<u>7A</u>	<u>3C</u>	<u>8P</u>
Pacific	Power Equipment Operators-Underground Sewer & Water	Dozers D-9 & Under	\$54.33	<u>7A</u>	<u>3C</u>	<u>8P</u>
Pacific	Power Equipment Operators-Underground Sewer & Water	Drill Oilers: Auger Type, Truck Or Crane Mount	\$54.33	<u>7A</u>	<u>3C</u>	<u>8P</u>
Pacific	Power Equipment Operators-Underground Sewer & Water	Drilling Machine	\$54.75	<u>7A</u>	<u>3C</u>	<u>8P</u>
Pacific	Power Equipment Operators-Underground Sewer & Water	Elevator And Man-lift: Permanent And Shaft Type	\$51.97	<u>7A</u>	<u>3C</u>	<u>8P</u>
Pacific	Power Equipment Operators-Underground Sewer & Water	Finishing Machine, Bidwell And Gamaco & Similar Equipment	\$54.75	<u>7A</u>	<u>3C</u>	<u>8P</u>
Pacific	Power Equipment Operators-Underground Sewer & Water	Forklift: 3000 Lbs And Over With Attachments	\$54.33	<u>7A</u>	<u>3C</u>	<u>8P</u>
Pacific	Power Equipment Operators-Underground Sewer & Water	Forklifts: Under 3000 Lbs. With Attachments	\$51.97	<u>7A</u>	<u>3C</u>	<u>8P</u>
Pacific	Power Equipment Operators-Underground Sewer & Water	Grade Engineer: Using Blueprints, Cut Sheets,etc.	\$54.75	<u>7A</u>	<u>3C</u>	<u>8P</u>
Pacific	Power Equipment Operators-Underground Sewer & Water	Gradechecker/stakeman	\$51.97	<u>7A</u>	<u>3C</u>	<u>8P</u>
Pacific	Power Equipment Operators-Underground Sewer & Water	Guardrail Punch	\$54.75	<u>7A</u>	<u>3C</u>	<u>8P</u>
Pacific	Power Equipment Operators-Underground Sewer & Water	Hard Tail End Dump Articulating Off- Road Equipment 45 Yards. & Over	\$55.24	<u>7A</u>	<u>3C</u>	<u>8P</u>
Pacific	Power Equipment Operators-Underground Sewer & Water	Hard Tail End Dump Articulating Off-road Equipment Under 45 Yards	\$54.75	<u>7A</u>	<u>3C</u>	<u>8P</u>
Pacific	Power Equipment Operators-Underground Sewer & Water	Horizontal/directional Drill Locator	\$54.33	<u>7A</u>	<u>3C</u>	<u>8P</u>
Pacific	Power Equipment Operators-Underground Sewer & Water	Horizontal/directional Drill Operator	\$54.75	<u>7A</u>	<u>3C</u>	<u>8P</u>
Pacific	Power Equipment Operators-Underground Sewer & Water	Hydralifts/Boom Trucks Over 10 Tons	\$54.33	<u>7A</u>	<u>3C</u>	<u>8P</u>
Pacific	Power Equipment Operators-Underground Sewer & Water	Hydralifts/boom Trucks, 10 Tons And Under	\$51.97	<u>7A</u>	<u>3C</u>	<u>8P</u>
Pacific	Power Equipment Operators-Underground Sewer & Water	Loader, Overhead 8 Yards. & Over	\$55.79	<u>7A</u>	<u>3C</u>	<u>8P</u>
Pacific	Power Equipment Operators-Underground Sewer & Water	Loader, Overhead, 6 Yards. But Not Including 8 Yards	\$55.24	<u>7A</u>	<u>3C</u>	<u>8P</u>
Pacific	Power Equipment Operators-Underground Sewer & Water	Loaders, Overhead Under 6 Yards	\$54.75	<u>7A</u>	<u>3C</u>	<u>8P</u>
Pacific	Power Equipment Operators-Underground Sewer & Water	Loaders, Plant Feed	\$54.75	<u>7A</u>	<u>3C</u>	<u>8P</u>

Pacific	Power Equipment Operators-Underground Sewer & Water	Loaders: Elevating Type Belt	\$54.33	<u>7A</u>	<u>3C</u>	<u>8P</u>
Pacific	Power Equipment Operators-Underground Sewer & Water	Locomotives, All	\$54.75	<u>7A</u>	<u>3C</u>	<u>8P</u>
Pacific	Power Equipment Operators-Underground Sewer & Water	Material Transfer Device	\$54.75	<u>7A</u>	<u>3C</u>	<u>8P</u>
Pacific	Power Equipment Operators-Underground Sewer & Water	Mechanics, All (Leadmen - \$0.50 Per Hour Over Mechanic)	\$55.79	<u>7A</u>	<u>3C</u>	<u>8P</u>
Pacific	Power Equipment Operators-Underground Sewer & Water	Motor Patrol Grader - Non-finishing	\$54.33	<u>7A</u>	<u>3C</u>	<u>8P</u>
Pacific	Power Equipment Operators-Underground Sewer & Water	Motor Patrol Graders, Finishing	\$55.24	<u>7A</u>	<u>3C</u>	<u>8P</u>
Pacific	Power Equipment Operators-Underground Sewer & Water	Mucking Machine, Mole, Tunnel Drill, Boring, Road Header And/or Shield	\$55.24	<u>7A</u>	<u>3C</u>	<u>8P</u>
Pacific	Power Equipment Operators-Underground Sewer & Water	Oil Distributors, Blower Distribution & Mulch Seeding Operator	\$51.97	<u>7A</u>	<u>3C</u>	<u>8P</u>
Pacific	Power Equipment Operators-Underground Sewer & Water	Outside Hoists (elevators And Manlifts), Air Tuggers, strato	\$54.33	<u>7A</u>	<u>3C</u>	<u>8P</u>
Pacific	Power Equipment Operators-Underground Sewer & Water	Overhead, Bridge Type Crane: 20 Tons Through 44 Tons	\$54.75	<u>7A</u>	<u>3C</u>	<u>8P</u>
Pacific	Power Equipment Operators-Underground Sewer & Water	Overhead, Bridge Type: 100 Tons And Over	\$55.79	<u>7A</u>	<u>3C</u>	<u>8P</u>
Pacific	Power Equipment Operators-Underground Sewer & Water	Overhead, Bridge Type: 45 Tons Through 99 Tons	\$55.24	<u>7A</u>	<u>3C</u>	<u>8P</u>
Pacific	Power Equipment Operators-Underground Sewer & Water	Pavement Breaker	\$51.97	<u>7A</u>	<u>3C</u>	<u>8P</u>
Pacific	Power Equipment Operators-Underground Sewer & Water	Pile Driver (other Than Crane Mount)	\$54.75	<u>7A</u>	<u>3C</u>	<u>8P</u>
Pacific	Power Equipment Operators-Underground Sewer & Water	Plant Oiler - Asphalt, Crusher	\$54.33	<u>7A</u>	<u>3C</u>	<u>8P</u>
Pacific	Power Equipment Operators-Underground Sewer & Water	Posthole Digger, Mechanical	\$51.97	<u>7A</u>	<u>3C</u>	<u>8P</u>
Pacific	Power Equipment Operators-Underground Sewer & Water	Power Plant	\$51.97	<u>7A</u>	<u>3C</u>	<u>8P</u>
Pacific	Power Equipment Operators-Underground Sewer & Water	Pumps - Water	\$51.97	<u>7A</u>	<u>3C</u>	<u>8P</u>
Pacific	Power Equipment Operators-Underground Sewer & Water	Quad 9, HD 41, D10 And Over	\$55.24	<u>7A</u>	<u>3C</u>	<u>8P</u>
Pacific	Power Equipment Operators-Underground Sewer & Water	Quick Tower - No Cab, Under 100 Feet In Height Based To Boom	\$51.97	<u>7A</u>	<u>3C</u>	<u>8P</u>
Pacific	Power Equipment Operators-Underground Sewer & Water	Remote Control Operator On Rubber Tired Earth Moving Equipment	\$55.24	<u>7A</u>	<u>3C</u>	<u>8P</u>
Pacific	Power Equipment Operators-Underground Sewer & Water	Rigger And Bellman	\$51.97	<u>7A</u>	<u>3C</u>	<u>8P</u>
Pacific	Power Equipment Operators-Underground Sewer & Water	Rollagon	\$55.24	<u>7A</u>	<u>3C</u>	<u>8P</u>

Pacific	Power Equipment Operators-Underground Sewer & Water	Roller, Other Than Plant Mix	\$51.97	<u>7A</u>	<u>3C</u>	<u>8P</u>
Pacific	Power Equipment Operators-Underground Sewer & Water	Roller, Plant Mix Or Multi-lift Materials	\$54.33	<u>7A</u>	<u>3C</u>	<u>8P</u>
Pacific	Power Equipment Operators-Underground Sewer & Water	Roto-mill, Roto-grinder	\$54.75	<u>7A</u>	<u>3C</u>	<u>8P</u>
Pacific	Power Equipment Operators-Underground Sewer & Water	Saws - Concrete	\$54.33	<u>7A</u>	<u>3C</u>	<u>8P</u>
Pacific	Power Equipment Operators-Underground Sewer & Water	Scraper, Self Propelled Under 45 Yards	\$54.75	<u>7A</u>	<u>3C</u>	<u>8P</u>
Pacific	Power Equipment Operators-Underground Sewer & Water	Scrapers - Concrete & Carry All	\$54.33	<u>7A</u>	<u>3C</u>	<u>8P</u>
Pacific	Power Equipment Operators-Underground Sewer & Water	Scrapers, Self-propelled: 45 Yards And Over	\$55.24	<u>7A</u>	<u>3C</u>	<u>8P</u>
Pacific	Power Equipment Operators-Underground Sewer & Water	Service Engineers - Equipment	\$54.33	<u>7A</u>	<u>3C</u>	<u>8P</u>
Pacific	Power Equipment Operators-Underground Sewer & Water	Shotcrete/gunite Equipment	\$51.97	<u>7A</u>	<u>3C</u>	<u>8P</u>
Pacific	Power Equipment Operators-Underground Sewer & Water	Shovel , Excavator, Backhoe, Tractors Under 15 Metric Tons.	\$54.33	<u>7A</u>	<u>3C</u>	<u>8P</u>
Pacific	Power Equipment Operators-Underground Sewer & Water	Shovel, Excavator, Backhoe: Over 30 Metric Tons To 50 Metric Tons	\$55.24	<u>7A</u>	<u>3C</u>	<u>8P</u>
Pacific	Power Equipment Operators-Underground Sewer & Water	Shovel, Excavator, Backhoes, Tractors: 15 To 30 Metric Tons	\$54.75	<u>7A</u>	<u>3C</u>	<u>8P</u>
Pacific	Power Equipment Operators-Underground Sewer & Water	Shovel, Excavator, Backhoes: Over 50 Metric Tons To 90 Metric Tons	\$55.79	<u>7A</u>	<u>3C</u>	<u>8P</u>
Pacific	Power Equipment Operators-Underground Sewer & Water	Shovel, Excavator, Backhoes: Over 90 Metric Tons	\$56.36	<u>7A</u>	<u>3C</u>	<u>8P</u>
Pacific	Power Equipment Operators-Underground Sewer & Water	Slipform Pavers	\$55.24	<u>7A</u>	<u>3C</u>	<u>8P</u>
Pacific	Power Equipment Operators-Underground Sewer & Water	Spreader, Topsider & Screedman	\$55.24	<u>7A</u>	<u>3C</u>	<u>8P</u>
Pacific	Power Equipment Operators-Underground Sewer & Water	Subgrader Trimmer	\$54.75	<u>7A</u>	<u>3C</u>	<u>8P</u>
Pacific	Power Equipment Operators-Underground Sewer & Water	Tower Bucket Elevators	\$54.33	<u>7A</u>	<u>3C</u>	<u>8P</u>
Pacific	Power Equipment Operators-Underground Sewer & Water	Tower Crane Over 175'in Height, Base To Boom	\$56.36	<u>7A</u>	<u>3C</u>	<u>8P</u>
Pacific	Power Equipment Operators-Underground Sewer & Water	Tower Crane: Up To 175' In Height, Base To Boom	\$55.79	<u>7A</u>	<u>3C</u>	<u>8P</u>
Pacific	Power Equipment Operators-Underground Sewer & Water	Transporters, All Track Or Truck Type	\$55.24	<u>7A</u>	<u>3C</u>	<u>8P</u>
Pacific	Power Equipment Operators-Underground Sewer & Water	Trenching Machines	\$54.33	<u>7A</u>	<u>3C</u>	<u>8P</u>
Pacific	Power Equipment Operators-Underground Sewer & Water	Truck Crane Oiler/driver - 100 Tons And Over	\$54.75	<u>7A</u>	<u>3C</u>	<u>8P</u>
Pacific	Power Equipment Operators-Underground Sewer & Water	Truck Crane Oiler/driver Under 100 Tons	\$54.33	<u>7A</u>	<u>3C</u>	<u>8P</u>

Pacific	Power Equipment Operators-Underground Sewer & Water	Truck Mount Portable Conveyor	\$54.75	<u>7A</u>	<u>3C</u>	<u>8P</u>
Pacific	Power Equipment Operators-Underground Sewer & Water	Welder	\$55.24	<u>7A</u>	<u>3C</u>	<u>8P</u>
Pacific	Power Equipment Operators-Underground Sewer & Water	Wheel Tractors, Farmall Type	\$51.97	<u>7A</u>	<u>3C</u>	<u>8P</u>
Pacific	Power Equipment Operators-Underground Sewer & Water	Yo Yo Pay Dozer	\$54.75	<u>7A</u>	<u>3C</u>	<u>8P</u>
Pacific	Power Line Clearance Tree Trimmers	Journey Level In Charge	\$45.75	<u>5A</u>	<u>4A</u>	
Pacific	Power Line Clearance Tree Trimmers	Spray Person	\$43.38	<u>5A</u>	<u>4A</u>	
Pacific	Power Line Clearance Tree Trimmers	Tree Equipment Operator	\$45.75	<u>5A</u>	<u>4A</u>	
Pacific	Power Line Clearance Tree Trimmers	Tree Trimmer	\$40.84	<u>5A</u>	<u>4A</u>	
Pacific	Power Line Clearance Tree Trimmers	Tree Trimmer Groundperson	\$30.74	<u>5A</u>	<u>4A</u>	
Pacific	Refrigeration & Air Conditioning Mechanics	Mechanic	\$64.86	<u>5A</u>	<u>1G</u>	
Pacific	Residential Brick Mason	Journey Level	\$17.82		<u>1</u>	
Pacific	Residential Carpenters	Journey Level	\$17.94		<u>1</u>	
Pacific	Residential Cement Masons	Journey Level	\$25.55		<u>1</u>	
Pacific	Residential Drywall Applicators	Journey Level	\$40.14	<u>5D</u>	<u>4C</u>	
Pacific	Residential Drywall Tapers	Journey Level	\$10.02		<u>1</u>	
Pacific	Residential Electricians	Journey Level	\$28.83	<u>5A</u>	<u>1B</u>	
Pacific	Residential Glaziers	Journey Level	\$10.72		<u>1</u>	
Pacific	Residential Insulation Applicators	Journey Level	\$9.47		<u>1</u>	
Pacific	Residential Laborers	Journey Level	\$25.59		<u>1</u>	
Pacific	Residential Marble Setters	Journey Level	\$17.82		<u>1</u>	
Pacific	Residential Painters	Journey Level	\$9.79		<u>1</u>	
Pacific	Residential Plumbers & Pipefitters	Journey Level	\$22.95		<u>1</u>	
Pacific	Residential Refrigeration & Air Conditioning Mechanics	Journey Level	\$9.47		<u>1</u>	
Pacific	Residential Sheet Metal Workers	Journey Level (Field or Shop)	\$30.73		<u>1</u>	
Pacific	Residential Soft Floor Layers	Journey Level	\$10.88		<u>1</u>	
Pacific	Residential Sprinkler Fitters (Fire Protection)	Journey Level	\$9.47		<u>1</u>	
Pacific	Residential Stone Masons	Journey Level	\$17.82		<u>1</u>	
Pacific	Residential Terrazzo Workers	Journey Level	\$9.47		<u>1</u>	
Pacific	Residential Terrazzo/Tile Finishers	Journey Level	\$9.47		<u>1</u>	
Pacific	Residential Tile Setters	Journey Level	\$9.47		<u>1</u>	
Pacific	Roofers	Journey Level	\$37.03		<u>1</u>	

Pacific	Sheet Metal Workers	Journey Level (Field or Shop)	\$70.37	<u>7E</u>	<u>1E</u>	
Pacific	Sign Makers & Installers (Electrical)	Journey Level	\$18.04		<u>1</u>	
Pacific	Sign Makers & Installers (Non-Electrical)	Journey Level	\$18.04		<u>1</u>	
Pacific	Soft Floor Layers	Journey Level	\$10.88		<u>1</u>	
Pacific	Solar Controls For Windows	Journey Level	\$10.31		<u>1</u>	
Pacific	Sprinkler Fitters (Fire Protection)	Journey Level	\$34.70		<u>1</u>	
Pacific	Stage Rigging Mechanics (Non Structural)	Journey Level	\$13.23		<u>1</u>	
Pacific	Stone Masons	Journey Level	\$51.32	<u>5A</u>	<u>1M</u>	
Pacific	Street And Parking Lot Sweeper Workers	Journey Level	\$16.00		<u>1</u>	
Pacific	Surveyors	All Classifications	\$44.15	<u>Null</u>	<u>1</u>	
Pacific	Telecommunication Technicians	Journey Level	\$12.07		<u>1</u>	
Pacific	Telephone Line Construction - Outside	Cable Splicer	\$36.96	<u>5A</u>	<u>2B</u>	
Pacific	Telephone Line Construction - Outside	Hole Digger/Ground Person	\$20.49	<u>5A</u>	<u>2B</u>	
Pacific	Telephone Line Construction - Outside	Installer (Repairer)	\$35.40	<u>5A</u>	<u>2B</u>	
Pacific	Telephone Line Construction - Outside	Special Aparatus Installer I	\$36.96	<u>5A</u>	<u>2B</u>	
Pacific	Telephone Line Construction - Outside	Special Apparatus Installer II	\$36.19	<u>5A</u>	<u>2B</u>	
Pacific	Telephone Line Construction - Outside	Telephone Equipment Operator (Heavy)	\$36.96	<u>5A</u>	<u>2B</u>	
Pacific	Telephone Line Construction - Outside	Telephone Equipment Operator (Light)	\$34.34	<u>5A</u>	<u>2B</u>	
Pacific	Telephone Line Construction - Outside	Telephone Lineperson	\$34.34	<u>5A</u>	<u>2B</u>	
Pacific	Telephone Line Construction - Outside	Television Groundperson	\$19.45	<u>5A</u>	<u>2B</u>	
Pacific	Telephone Line Construction - Outside	Television Lineperson/Installer	\$25.89	<u>5A</u>	<u>2B</u>	
Pacific	Telephone Line Construction - Outside	Television System Technician	\$30.97	<u>5A</u>	<u>2B</u>	
Pacific	Telephone Line Construction - Outside	Television Technician	\$27.77	<u>5A</u>	<u>2B</u>	
Pacific	Telephone Line Construction - Outside	Tree Trimmer	\$34.34	<u>5A</u>	<u>2B</u>	
Pacific	Terrazzo Workers	Journey Level	\$46.96	<u>5A</u>	<u>1M</u>	
Pacific	Tile Setters	Journey Level	\$46.96	<u>5A</u>	<u>1M</u>	
Pacific	Tile, Marble & Terrazzo Finishers	Finisher	\$37.79	<u>5A</u>	<u>1B</u>	
Pacific	Traffic Control Stripers	Journey Level	\$44.51	<u>7P</u>	<u>1K</u>	

Pacific	Truck Drivers	Asphalt Mix Over 16 Yards (W. WA-Joint Council 28)	\$49.85	<u>5D</u>	<u>3A</u>	<u>8L</u>
Pacific	Truck Drivers	Asphalt Mix To 16 Yards (W. WA-Joint Council 28)	\$49.01	<u>5D</u>	<u>3A</u>	<u>8L</u>
Pacific	Truck Drivers	Dump Truck	\$17.98		<u>1</u>	
Pacific	Truck Drivers	Dump Truck And Trailer	\$17.98		<u>1</u>	
Pacific	Truck Drivers	Other Trucks	\$21.54		<u>1</u>	
Pacific	Truck Drivers	Transit Mixer	\$22.31		<u>1</u>	
Pacific	Well Drillers & Irrigation Pump Installers	Irrigation Pump Installer	\$11.60		<u>1</u>	
Pacific	Well Drillers & Irrigation Pump Installers	Oiler	\$9.47		<u>1</u>	
Pacific	Well Drillers & Irrigation Pump Installers	Well Driller	\$11.60		<u>1</u>	

PART 4 – PLANS

NORTH WELLFIELD SEPTIC SYSTEM INSTALLATION REQUEST FOR BIDS

JUNE, 2015

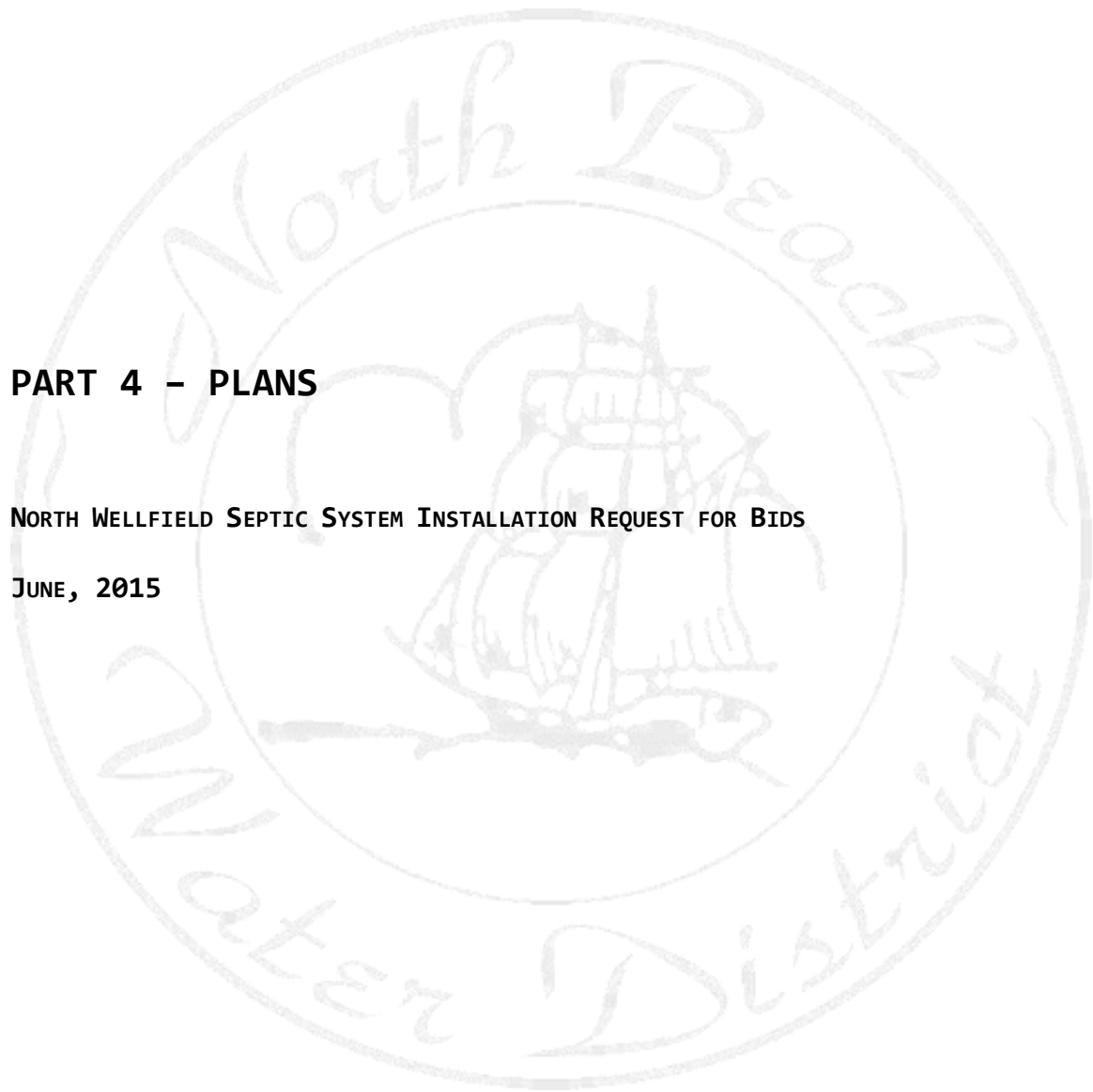

Vicinity Map #1



Location Map #2



Location Map #3

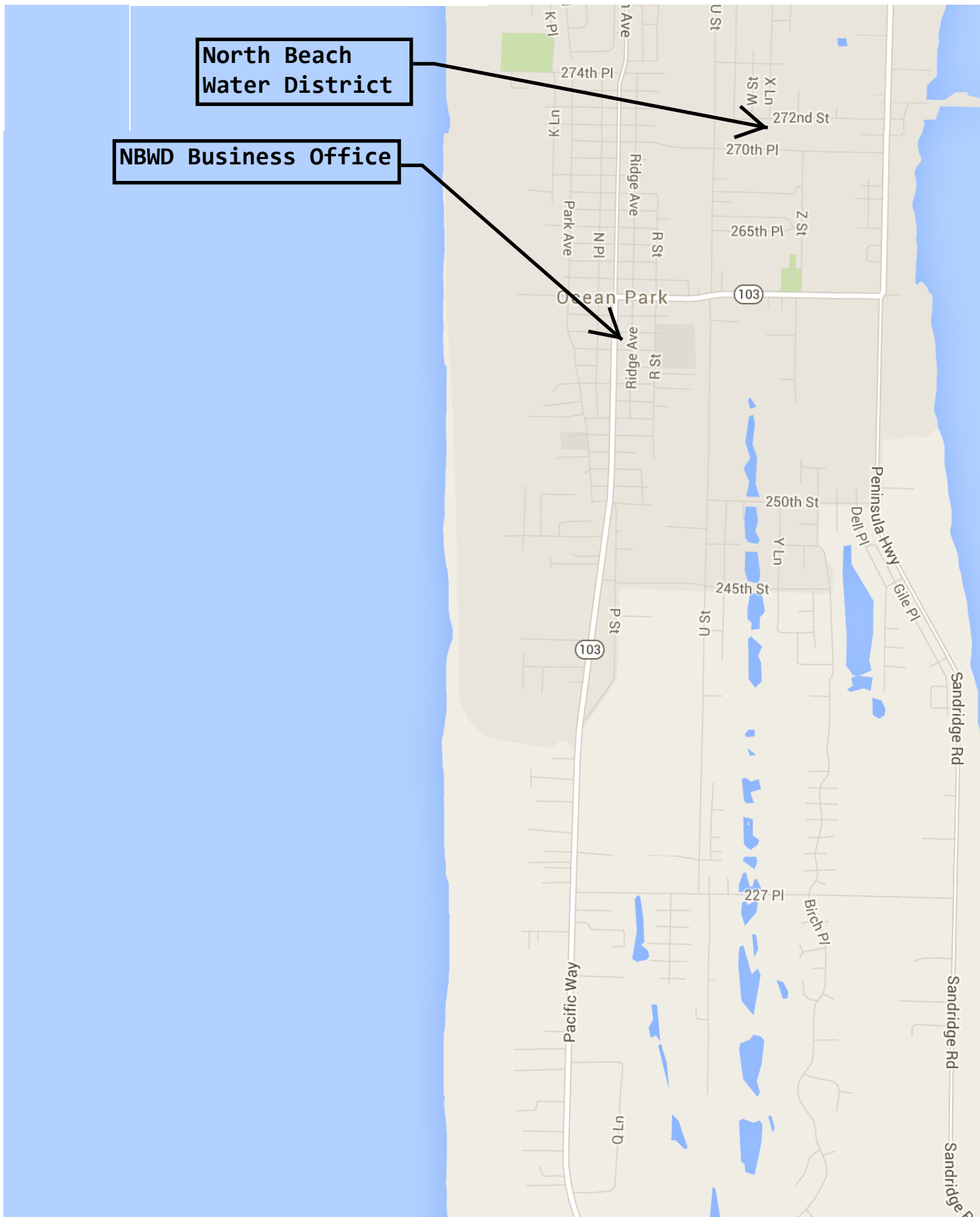

OWNER: NORTH BEACH WATER DISTRICT
MAIL ADDRESS: P.O. BOX 618, OCEAN PARK, WA 98640
SITE ADDRESS: 2320 272nd STREET
LEGAL: SAILFISH 01, 07 (T12N, R11W, SEC. 28)
PARCEL: 750206001007
DIRCTIONS: OCEAN PARK TO "U", N. TO 272ND

CLIENT: NORTH BEACH WATER DISTRICT
PROJECT: SEPTIC SYSTEM
WATER SOURCE: PUBLIC WATER
PROPERTY USE: WATER WELLS & TREATMENT
TYPE OF SYSTEM: GRAVITY

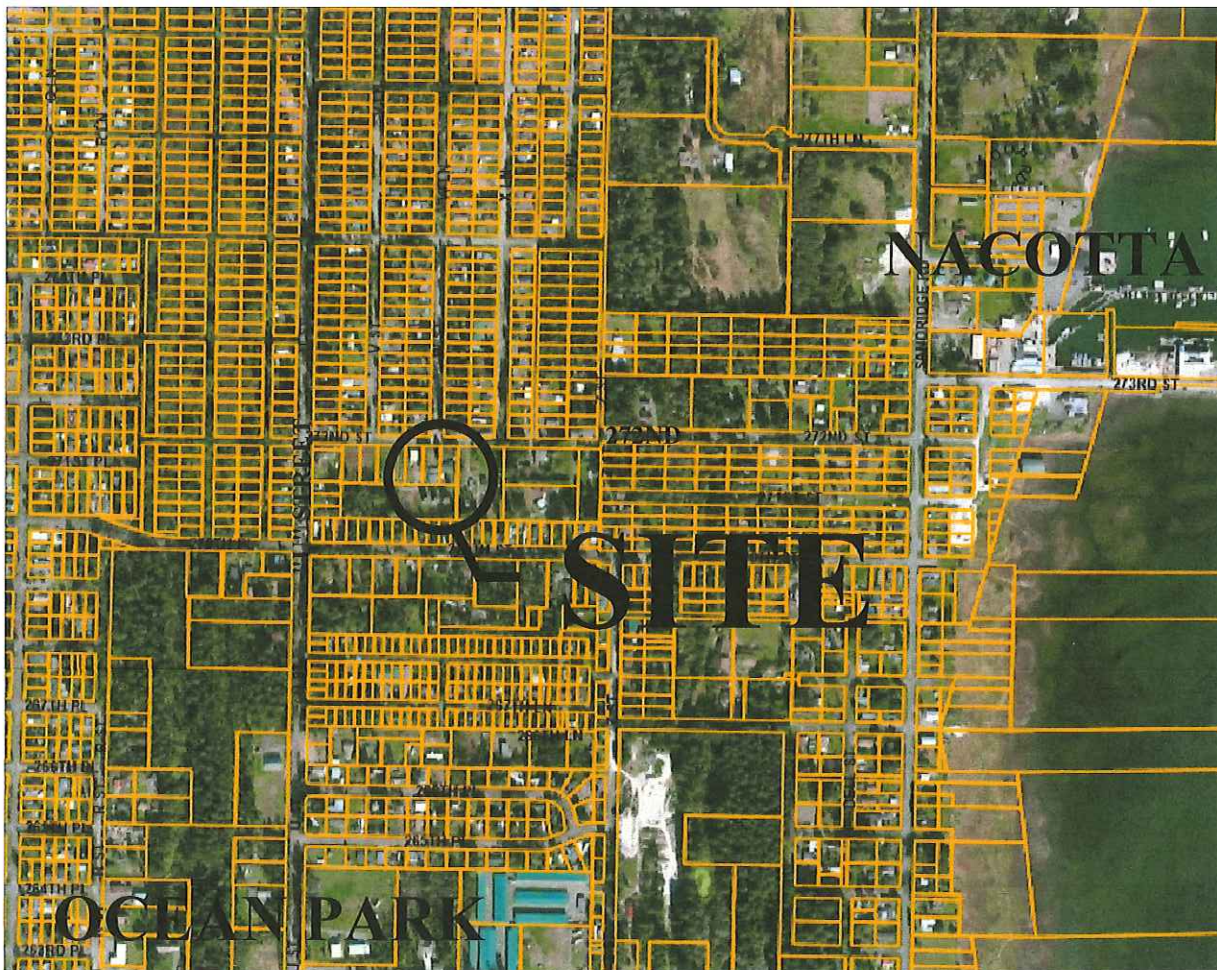

LOCATION

U
A *Utti & Associates*
 Planning & Engineering

P. O. Box 482
 Gearhart, OR 97138
 (503) 717-1519

email:
 uttiandassocites@msn.com

SEPTIC SYSTEM - COVER SHEET

Parcel # 75026001007
 2320 272nd Street, Ocean Park 98640
 Project: 275-15

Date: Mar. 15, 2015
 Scale: N/A
 SHEET NO. 1

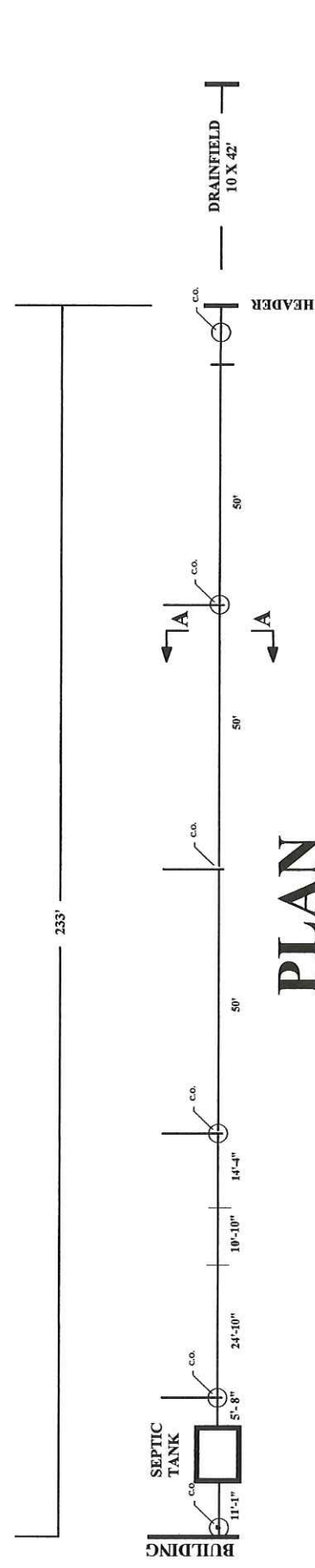

PLAN

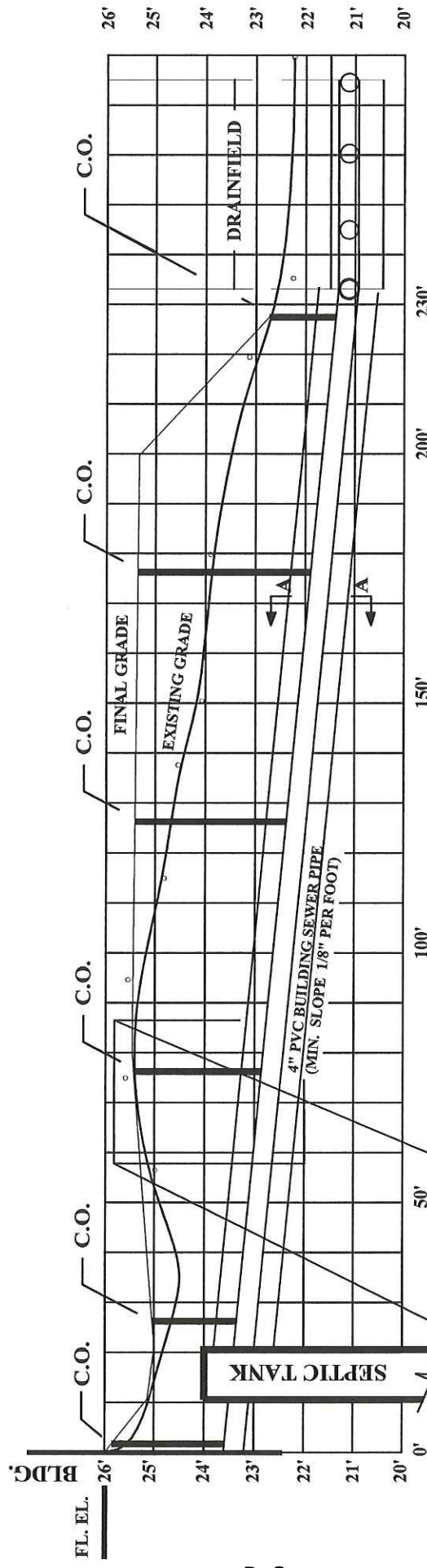

PROFILE

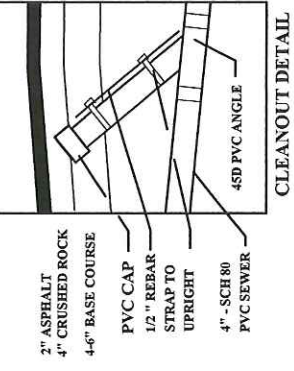
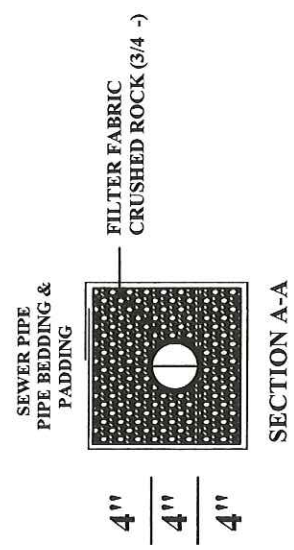

SEPTIC SYSTEM - PROFILE
 Parcel # 75026001007
 Date: Mar. 15, 2015
 Scale: N/A
 Project: 275-15
 SHEET NO. 3

P. O. Box 482
 Gearhart, OR 97138
 (503) 717-1519
 email: uttiandassociates@msn.com

Utti & Associates
 Planning & Engineering





PROPERTY LINE

RESERVE
400 SF

PRIMARY
> 400 SF

8" water

2' SETBACK

Min.
10'

42.5' X 10'

10'

T-2

T-1

CURB AND/OR LANDSCAPING

LONG RADIUS

C.O.

50'

OR
E

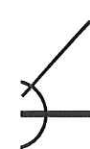
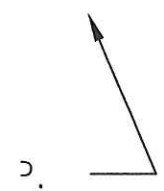

U
A

Utti & Associates
Planning & Engineering

P. O. Box 482
Gearhart, OR 97138
(503) 717-1519
email:
uttilandassocites@msn.com

SEPTIC SYTSETM - SITE PLAN

Parcel # 75026001007
2320 272nd Street, Ocean Park 98460
Project: 275-15

Date: Mar. 15, 2015
Scale: N/A
SHEET NO. 4

A-1 1250 Gallon Concrete Septic Tank

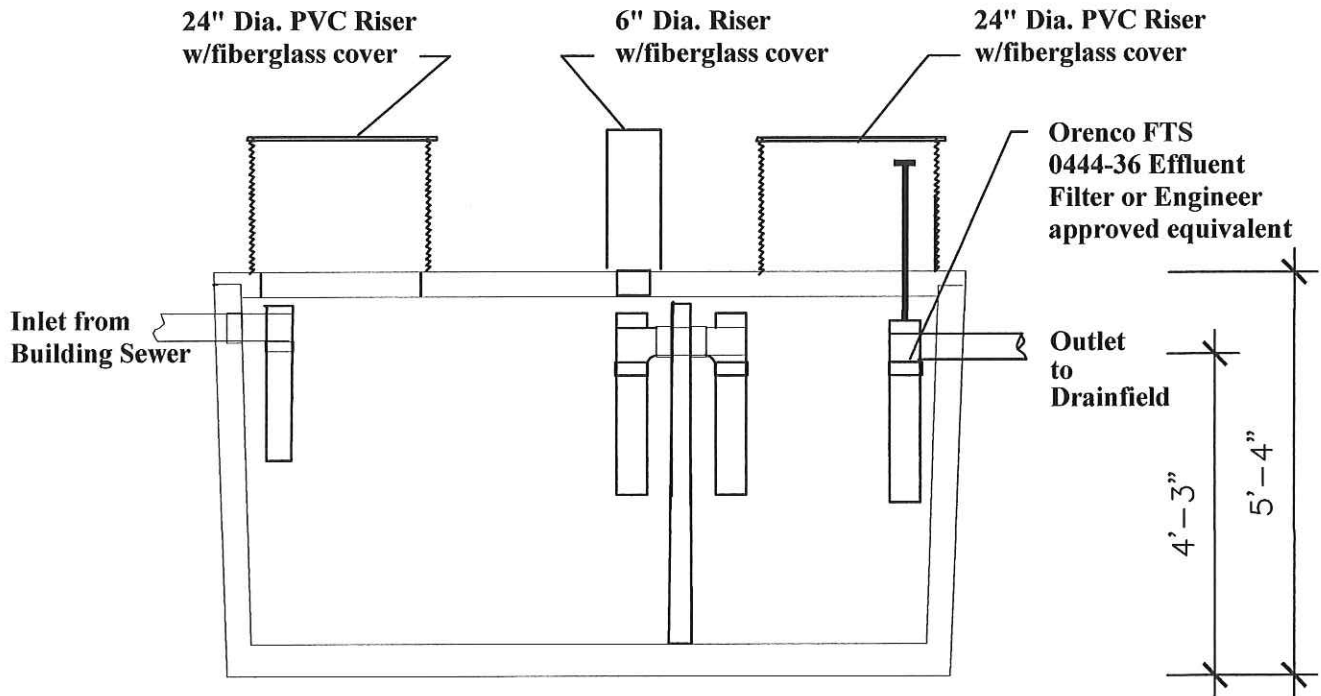
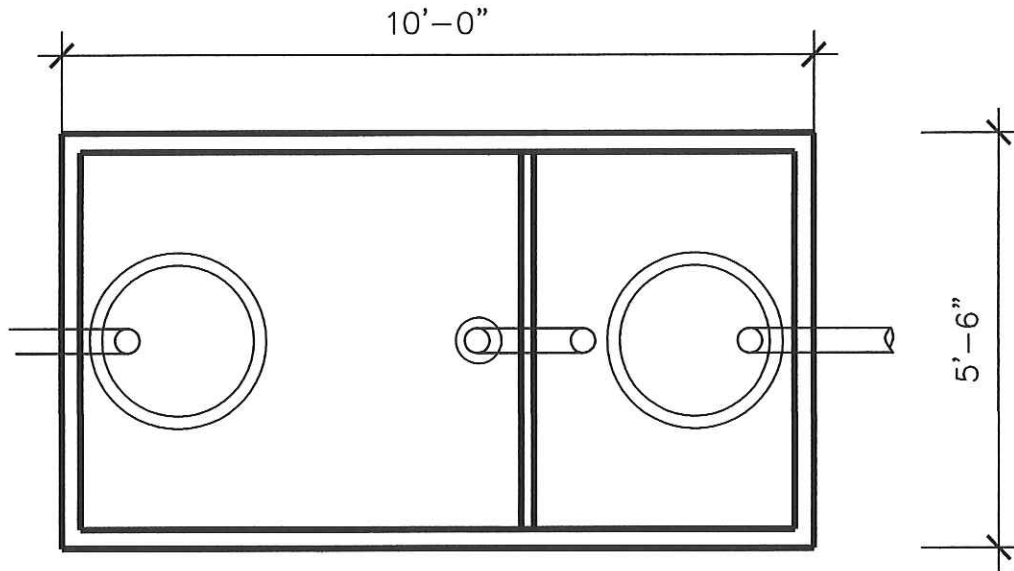

D-5



TOP VIEW OF DRAINFIELD

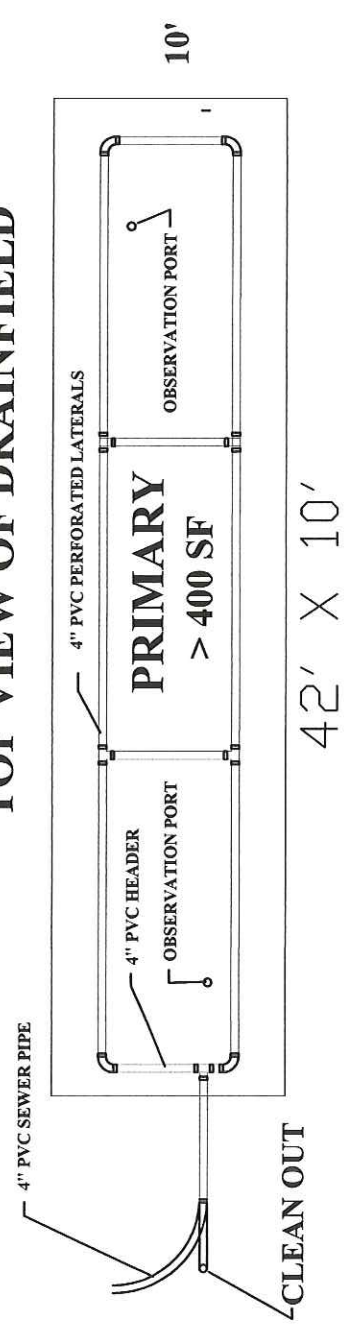

BED SECTION

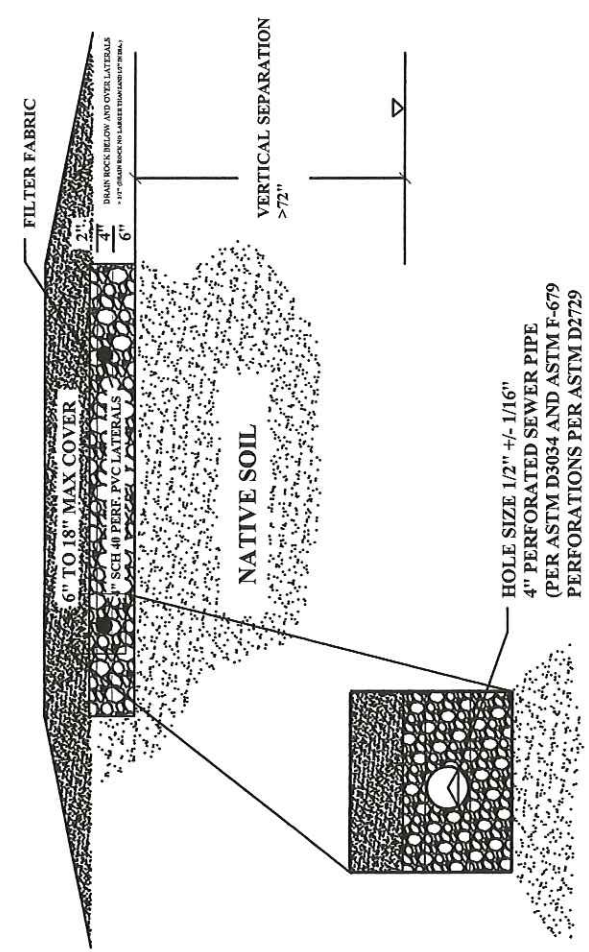

OBSERVATION PORT DETAIL

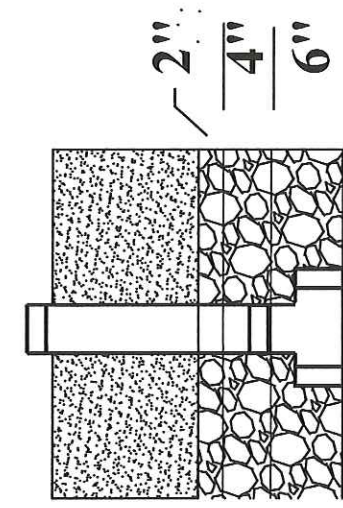

SEPTIC SYSTEM - BED DETAILS

Date: Mar. 15, 2015
 Scale: N/A
 SHEET NO. 6

P. O. Box 482
 Gearhart, OR 97138
 (503) 717-1519
 email: uttianassociates@msn.com

UA
 Utti & Associates
 Planning & Engineering

STANDARDS:

GENERAL:

The installation and installer shall conform with all federal, state, county and local regulations. Alternative materials shall be approved by the engineer prior to use.

It is the installers responsibility to investigte the site and report conditions not anticipated.

Any work done contrary to the design without prior approval will be the installers responsibility to correct at the installer's expense. If conditions are encountered on-site that require modification of the design, it shall be the installer's responsibility to inform the owner and engineer as soon as those conditions are encountered.

SAFETY:

The installer shall be responsible for obtaining all utility locates prior to starting any work on site. The method for performing the work shall be in compliance with all state and federal laws. No work shall be performed that jeopardizes the safety of others on site. Warning flags, signs or barricades shall be provided to protect others from entering dangerous conditions created by construction activities on the property. No excavation for tanks, trenches, drainfields or test holes shall be left unattended during construction or without covers or barricades to prevent children or others from entering areas with a threat or potential hazard to personal safety.

It is the responsibility of the contractor to maintain all baracades, signs or covers during the period of construction from start of construction to completion. Inspections will be called for by the installer at each phase of construction, prior to placing cover over the the work complete.

MISC. REQUIREMENTS:

The installer shall be responsible for installation of landscaping, fencing, barriers or curbing to prevent vehicles from driving onto the primary or reserve drainfield areas.

The grade of the bottom of the drainfield trenches and drainfield lines shall be level (+ or - one inch)

The max. depth of cover over the absorption system shall not exceed eighteen (18) inches.

The min. depth of cover shall not be less than six (6) inches.

The distribution pipe must be installed in native soil;

The bottom of the SSAS shall not be deeper than twenty four (24) inches below finish grade.

The min. depth of drain rock under drainfield lines shall not be less than six (6) inches.

The amount of drain rock over drainfield lines shall not be less than two (2) inches.

The min. distance between drainfield lines shall not be less than eight (8) feet.

The min. diameter of gravity lines shall not be less than four (4) inches. Diameter of pressure lines shall be as specified and meet DOH specificatins in the DOH Pressure guidelines.

Gravity sewer line shall be not less than four (4) inches in diameter with slope between 1/8th to 1/4 in./foot.



MAJOR MATERIALS:

BUILDING SEWER:

1. < 12' Four (4) inch PVC Sewer Pipe
2. 1 ea - Cleanout

SEPTIC TANK:

1. 1,250 Gallon Septic Tank (two compartments)
2. 2 ea. - 24" dia. PVC corrugated risers
3. 2 ea. - 24" dia. fiberglass lids with gaskets
4. 1 ea. - Orenco effluent filter (or equivalent)

DISTRIBUTION SEWER LINE:

1. Approx. 216' of four (4) inch Sch. 40 pvc pipe for transport to drainfield
2. Four (4) inch pvc elbows, bends, cleanouts consistent with those shown on the drawings
3. Misc. materials to complet the installation per the drawings
4. Drain rock as bedding and padding as shown on the drawing
5. Trench subgrade shall be compacted to 95% or greater density
6. Trench padding and fill to grade shall be compacted to 95% or greater density
7. Filter fabric shall be placed around drain rock.

DRAINFIELD:

1. 104' of 4.00" dia. pvc perforated drain pipe
2. 4- four (4) inch dia. sch. 40 pvc elbows
3. 5- four (4) inch dia. sch. 40 tees
4. four (4) hundred squar feet of approved geotextile filter fabric to cover drainrock
5. Four inch dia. pipe, elbows, tees and caps for the two (2) observation port(s).
6. Approved drain rock per County and State specifications.



To: Bidders
E-mail: [enter e-mail address]



ADDENDUM #1

Date of Addendum: 6/16/2015

RFP----- North Wellfield Septic System Installation
Release Date----- 6/10/2015
Due Date----- 11:00 AM 6/25/15

NOTICE TO ALL PROPOSERS:

The specifications for the above-referenced RFP are modified as set forth in this Addendum. The original RFP Documents and any previously issued addenda remain in full force and effect, except as modified by this Addendum, which is hereby made part of the RFP Documents. Bidders shall take this Addendum into consideration when preparing and submitting a Bid, and shall acknowledge receipt of this Addendum by including reference to this Addendum on the Bid Form in the accordance with the Bidders Instructions therein.

BID SUBMITTAL DEADLINE:

The bid submittal deadline remains the same and is not changed by this Addendum.

DRAWING IN RFP:

Page-----	Section No.-----	Description -----
D-3----	Septic System Design---	Cleanout Detail calls for 4" Building Sewer Pipe to be SCH 80 PVC.

CORRECTION TO DRAWING IN RFP:

Page-----	Section No.-----	Description -----
D-3----	Septic System Design---	Building Sewer Pipe and all fittings shall be SCH 40 PVC.